

# WINDOW PARTS AND CLIPS

	PAGE
<b>POWER WINDOW PARTS</b>	
GEARS .....	110
MOTOR .....	102
SWITCHES .....	101
<b>VENT WINDOW PARTS</b>	
VENT PARTS .....	99
WEATHERSTRIPS .....	99
WEATHERSTRIP RETAINERS & CLIPS .....	78
WINDOW CHANNEL .....	100
<b>WINDOW REGULATOR &amp; CHANNEL ROLLERS AND PARTS</b>	
<b>CHRYSLER &amp; AMERICAN MOTORS</b>	
GLASS GUIDES .....	87
ROLLERS & PARTS .....	96
<b>FORD</b>	
ROLLERS & PARTS .....	93
<b>GENERAL MOTORS</b>	
GLASS GUIDES .....	83
ROLLERS & PARTS .....	88
TAPE CONTROLLED REGULATOR COMPONENTS ....	86
GENERAL USE ROLLERS .....	91
WINDOW REGULATOR REPAIR PARTS .....	100

## WEATHERSTRIP RETAINERS GENERAL MOTORS



**WP-1 (000950)**  
Replaces: 4770719  
**CLIP-DOOR WEATHERSTRIP**  
Plastic  
G.M. '59  
*UNIT PACKAGE 100*



**97-7664**  
Not Supplied By O.E.  
**CLIP, DOOR & QUARTER**  
**GLASS CHANNEL**  
Formerly SC-3166  
G.M. Cars  
*UNIT PACKAGE 50*



**SC-3344**  
Replaces: 4887979  
**CLIP-GLASS RUN CHANNEL**  
G.M. Trucks '63 - '64  
*UNIT PACKAGE 100*



**SC-3345**  
Replaces: 4887980  
**CLIP-GLASS RUN CHANNEL**  
G.M. Compact Cars '63 - '64  
*UNIT PACKAGE 100*

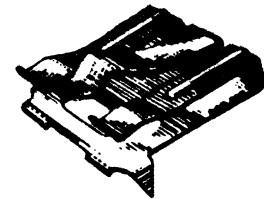

**72-3730**  
Replaces: 325338  
**CLIP-DOOR WEATHERSTRIP**  
G.M. '71 - '72  
*UNIT PACKAGE 50*

**SC-3346**

Replaces: 4412878  
**CLIP-GLASS RUN CHANNEL**  
G.M. '64 w/Center Tongue  
Shorter than SC-3345  
*UNIT PACKAGE 100*



**85-5973**  
**CLIP-DOOR & QUARTER GLASS**  
**OUTER WEATHER STRIP**  
G.M., Ford & Chrysler  
Some Imports  
*UNIT PACKAGE 50*



**66-1156**  
Replaces: 7586884  
**CLIP-WEATHERSTRIP &**  
**GLASS CHANNEL**  
G.M. Cars  
*UNIT PACKAGE 100*



**99-8033**  
Replaces: 4876498  
**CLIP-WEATHERSTRIP DOOR**  
Nylon, Opening Fastener  
Hole: M4.5, Head: 5x13MM, P.R. 6MM  
All G.M. Cars '63, Ford '65  
*UNIT PACKAGE 50*



**70-3422**  
Replaces: 8731909, 4841194  
**CLIP-WEATHERSTRIP**  
Hole: 1/8", Head: 3/8", P.R. 9/32"  
G.M. '63-2002  
*UNIT PACKAGE 100*

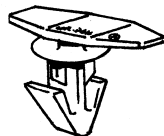

**98-7846**  
Replaces: 10283414, 10405030  
**CLIP-WEATHERSTRIP**  
Front & Rear Doors  
Plastic  
G.M. "W" Body '97/  
*UNIT PACKAGE 50*



**73-3906**  
Replaces: 3981457  
**CLIP-ROOF HEADER WEATHERSTRIP**  
Side Front Door Window Glass  
Weatherstrip  
Hole: 1/4", Head: 1/4" X 3/4", P.R.: 5/16"  
Blazer '71 - '72  
General Purpose  
*UNIT PACKAGE 100*

**88-6409**

Replaces: 20699808  
**CLIP-WEATHERSTRIP, FRONT BUMPER**  
 Plastic  
 Hole: M5, Head: 10MM, P.R.: 2.0-7.0MM  
 G.M. Various Models '86/  
*UNIT PACKAGE 100*

**96-7528**

Replaces: 20200750  
**CLIP-WEATHERSTRIP HOOD**  
 Hole: 11/64, Stem Length: 13/32"  
 Head: 13/64" x 1/2"  
 Natural Plastic  
 G.M. Various Models '70/  
*UNIT PACKAGE 100*

**J01962**

Replaces: 375372S, 1477728 & 3001419  
**RETAINER-w/STRIP**  
 Hole: 1/4"  
 Ford G.M. & Chrysler  
*UNIT PACKAGE 100*

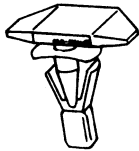
**93-7196**

Replaces: 4696129  
**CLIP-WEATHERSTRIP**  
**FRONT & REAR DOORS**  
 Plastic  
 Hole: M5, Head: 6.5 x 16.5MM,  
 P.R.: 1.5MM  
 Hummer H2, Chrysler "LH" '93/  
*UNIT PACKAGE 100*

**96-7550**

Replaces: 10169777  
**CLIP-WEATHERSTRIP DOORS**  
 Hole: M5, Head: 11MM  
 O/L: 9.5MM  
 Black Plastic  
 Chevrolet "W" Bodies '95/  
*UNIT PACKAGE 25*

**96-7609**

Replaces: 22567463  
**RETAINER- HOOD SEAL**  
 Plastic-Black  
 Hole Dia: M6.3, Stem Lgth: 16MM  
 Head Dia: 16MM  
 G.M. "N" Body '92/'93  
*UNIT PACKAGE 50*

**99-8551**

Replaces: 10293193, N811040-S  
**RETAINER-HOOD INSULATOR,**  
 Door w/Strip  
 Plastic  
 Hole: M7, Head: 12.6MM,  
 Stem Lgth: 15MM,  
 P.R.: 0.8-8.0MM, O/L: 17.5MM  
 Chevrolet Cobalt 2005, Ford Mustang 2005/  
*UNIT PACKAGE 50*

**99-8499**

Replaces: 002-997-33-86, 20538173  
**RETAINER-FRONT FENDER,**  
**WEATHERSTRIP**  
 Plastic  
 Hole: M4.75, Head: 11MM,  
 Stem Lgth.: 12MM, P.R.: 0.8-6.5MM  
 Mercedes C, CLK, E & SL Class '98/  
 G.M. '90/  
*UNIT PACKAGE 50*

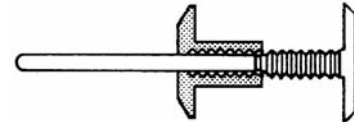
**99-8001**

Replaces: 15738538, 15738539  
**RIVET-SANDWICH TYPE**  
 Plastic - Side Door Weatherstrip  
 Hole: M5, Head: 12 x 22MM, PR.: 10MM  
 G.M. C/K Trucks '96/  
*UNIT PACKAGE 15*

**FORD****65-1111**

Replaces: C1AB-6229796-A  
**CLIP-DOOR FLANGE WEATHERSTRIP**  
 Natural Plastic  
 Hole: 5/32", Head: 3/8", P.R.: 5/32"  
 Ford Mercury '61  
*UNIT PACKAGE 100*

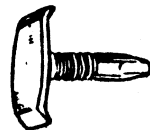
**68-3160**

Replaces: C5AB-6220586-A, 9882774  
**CLIP-DOOR WEATHERSTRIP, Nylon**  
 Hole: 3/16", Head: 3/16" x 1/2", P.R.: 1/4"  
 All Ford Products '66 - '68, G.M.  
*UNIT PACKAGE 50*  
**J02338**  
*UNIT PACKAGE 100*

**99-8033**

Replaces: 4876498  
**CLIP-DOOR WEATHERSTRIP**  
 Opening Fastener  
 Nylon  
 Hole: M4.5, Head: 5 x 13MM,  
 P.R.: 6MM  
 All G.M. Cars '63, Ford '65  
*UNIT PACKAGE 50*



**SC-3348**  
CLIP-GLASS RUN CHANNEL  
Ford Products  
UNIT PACKAGE 100



**99-8636**  
Not Supplied by O.E.  
CLIP-WEATHERSTRIP  
Ford  
UNIT PACKAGE 50



**72-3688**  
Replaces: 385325  
CLIP-WEATHERSTRIP  
Hole: 1/8", Head: 3/8"  
P.R.: 1/4"  
Ford Products  
UNIT PACKAGE 100

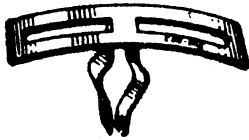

**76-4382**  
Replaces: 358567-52  
CLIP-WEATHERSTRIP  
Ford, Mercury '74  
UNIT PACKAGE 100



**97-7665**  
Replaces: 385677  
CLIP- WEATHERSTRIP  
Plastic  
Ford  
UNIT PACKAGE 100

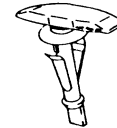

**92-7013**  
Not Available By OEM  
CLIP-WEATHERSTRIP  
Hole: 3/16", Head: 3/16" x 9/16",  
P.R.: .050  
Lincoln '89/, Expedition '97/  
UNIT PACKAGE 50



**98-7882**  
Not Supplied By O.E.  
RETAINER- BUMPER COVER,  
DOOR WEATHERSTRIP  
Plastic  
Hole: M5, Head: 13MM  
P.R.: 1.5 - 12.5MM  
Ford Contour & Mystique '95/  
& Taurus/Sable  
UNIT PACKAGE 50



**97-7702**  
Not Supplied By O.E.  
RETAINER - WEATHERSTRIP  
Plastic  
Hole: M5, Max PR.: 2.5-4MM  
Ford Windstar '95/  
UNIT PACKAGE 50



**99-8114**  
Replaces: N806289-S, N806340-S  
RETAINER- WEATHERSTRIP  
Plastic  
Hole: M4.8, Head: 5 x 15MM,  
P.R.: .8 - 1.95MM  
Ford F150 Pick Ups '97/  
UNIT PACKAGE 100



**99-8524**  
NOT SUPPLIED BY O.E.  
RETAINER-WEATHERSTRIP  
Plastic  
Hole: M7, Head: 10MM,  
Stem Lgth.: 14.5MM,  
P.R.: 1-2.4MM  
Ford 'F' Series Pick Up 2004/  
UNIT PACKAGE 100



**J01961**  
Replaces: C1AB-6220807A  
RETAINER-w/STRIP  
Hole: 3/16"  
Ford & Universal  
UNIT PACKAGE 100



**J01962**  
Replaces: 375372S, 1477728 & 3001419  
RETAINER-w/STRIP  
Hole: 1/4"  
Ford G.M. & Chrysler  
UNIT PACKAGE 100

**96-7608**

Replaces: 99264-05318, E92Z-6120586-A  
**CLIP-HOOD SEAL**  
 Front Door Weatherstrip  
 Plastic-Black  
 Hole Dia: M5, Stem Lgth: 15MM  
 Head Dia: 14MM  
 Ford Probe '90, Mazda  
*UNIT PACKAGE 25*

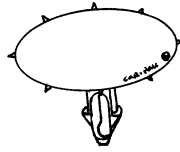
**99-8206**

Replaces: YS4Z-5420586-AA  
**RETAINER-WEATHERSTRIP**  
 Front Door  
 Plastic  
 Hole: M4, Head: 11MM, (Plus Points)  
 Ford Focus 2000/  
*UNIT PACKAGE 50*

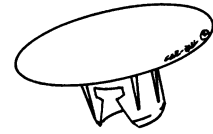
**98-7773**

Replaces: W702010-S300  
**CLIP-WEATHERSTRIP**  
 Body Side to Door-Upper  
 Plastic-Black  
 Hole: M5, Head: 16MM  
 Ford Contour & Mystique '95/  
*UNIT PACKAGE 25*

### CHRYSLER, AMC AND GENERAL PURPOSE

**99-8635**

**CLIP-GLASS RUN CHANNEL**  
 Formerly SC-3142  
 Passenger Cars & Trucks  
*UNIT PACKAGE 25*

**71-3483**

Replaces: 2217508  
**CLIP-OUTER WEATHERSTRIP DOOR  
 AND QUARTER WINDOW**  
 Chrysler '67 - '72  
*UNIT PACKAGE 100*

**73-3802**

Replaces: 3674096  
**CLIP-GLASS WEATHERSTRIP**  
 Chrysler Products  
*UNIT PACKAGE 100*

**68-3161 (J02340)**

Replaces: 2664040  
**CLIP-WEATHERSTRIP  
 TO INSIDE PANEL**  
 Nylon  
 Chrysler '66  
*UNIT PACKAGE 100*

**82-5510**

Replaces: 4040732  
**CLIP-DOOR WEATHERSTRIP TO INSIDE  
 PANEL. HOOD INNER PANEL TO COWL**  
 Hole: 1/4", Head: 9/32" x 9/16", P.R.: 1/4"  
 Chrysler '78  
*UNIT PACKAGE 100*

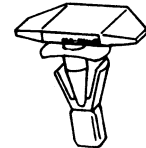
**93-7196**

Replaces: 4696129  
**CLIP-WEATHERSTRIP**  
 FRONT & REAR DOORS  
 Plastic  
 Hole: M5, Head: 6.5 x 16.5MM,  
 P.R.: 1.5MM  
 Hummer H2, Chrysler "LH" '93/  
*UNIT PACKAGE 100*

**93-7173**

Replaces: 4001916  
**CLIP-WEATHERSTRIP**  
 Nylon  
 Hole: 5/16", Head: 3/16" x 9/16",  
 P.R.: .050  
 Jeep & G.M. Trucks  
*UNIT PACKAGE 50*

**99-8013**

Not Supplied By O.E.  
**RETAINER-WEATHERSTRIP**  
 Plastic  
 Hole: M5, Head: 6.5 x 16.5MM  
 Chrysler LH, LHS '97/  
*UNIT PACKAGE 100*

**99-8515**

Not Supplied By O.E.  
**RETAINER-WEATHERSTRIP**  
 Plastic  
 Hole: M6, Head: 5x15MM,  
 O/L: 8.6MM, P.R.: 0.8-1.9MM  
 Chrysler 300 & Dodge Magnum 2005  
*UNIT PACKAGE 100*

**99-8012**

Not Supplied By O.E.  
**RETAINER-WEATHERSTRIP**  
 Plastic

Hole: M4.8, Head: 6.5 x 11MM, PR.: 8MM  
 Chrysler LH, LHS '97/  
*UNIT PACKAGE 100*

**99-8014**

Not Supplied By O.E.  
**RETAINER-WEATHERSTRIP**  
 Plastic

Hole: M5.2, Head: 6.5 x 16.5MM  
 Chrysler LH, LHS '97/  
*UNIT PACKAGE 100*

**97-7686**

Replaces: 4658673, 10293674  
**CLIP- DOOR WEATHERSTRIP**  
 Plastic

Hole Dia: M5, Stem Lgth: 15.5MM  
 Head Dia: 10MM  
 Chrysler Neon '95/ G.M.  
*UNIT PACKAGE 50*

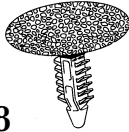
**97-7618**

Replaces N808842-S, W705002-S300,  
 6504098

**RETAINER, HOOD SEAL & INSULATOR**  
 Plastic

Hole Dia: M6.3, Stem Lgth: 17MM  
 Head Dia: 32MM

Ford Taurus '96/, Lincoln Mark VIII '97,  
 Ford Edge/MKX 2007/, Flex,  
 Escape/Mariner 2008/  
 Ford Lt. Trucks '96/, Chrysler Sebring '96/  
*UNIT PACKAGE 50*

**J01962**

Replaces: 375372S, 1477728 & 3001419

**RETAINER-w/STRIP**  
 Hole: 1/4"

Ford G.M. & Chrysler  
*UNIT PACKAGE 100*



[www.carpak.com](http://www.carpak.com)

## DOOR WINDOW GUIDES GENERAL MOTORS SNAP ON STYLE

WINDOW PARTS

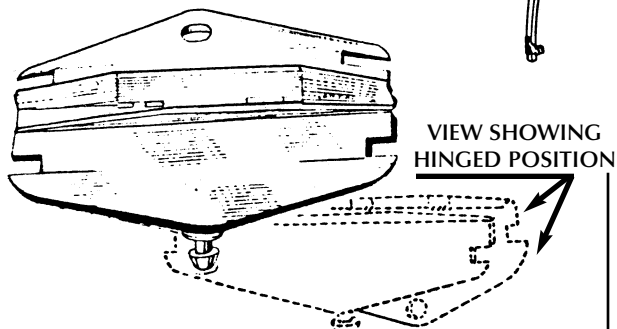
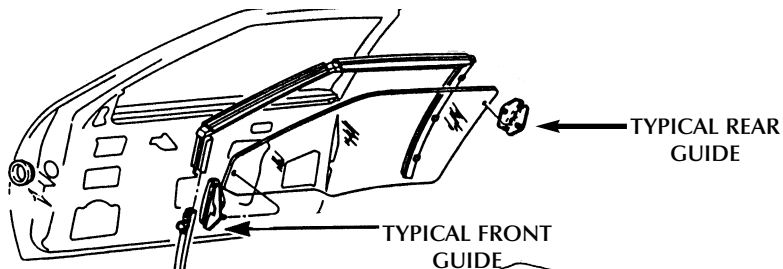

**80-5161**

Replaces: 10051034, 10114597, 12338011  
20123070 & 20328600

**GUIDE-FRONT DOOR WINDOW**

G.M. '80/, Buick  
Cadillac & Olds 'B', 'C' & 'X' Bodies  
S-Truck '82 - '90, 'A' Bodies '82 - '86  
*UNIT PACKAGE 25*

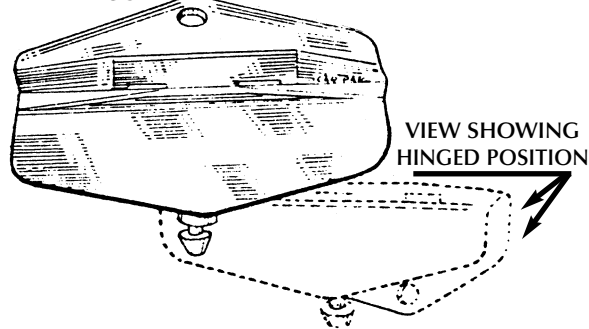

**80-5162**

Replaces: 20160591

**GUIDE-REAR DOOR WINDOW**

G.M. '80/ Wagons 'B', 'C' & 'X' Bodies  
*UNIT PACKAGE 25*

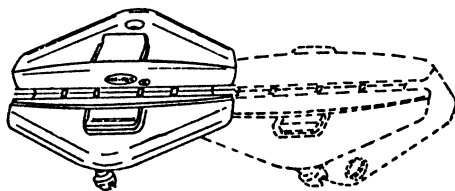

**85-5891**

Replaces: 20484630, 20712172 & 20712176, 12353912,  
20340710, 20633504

**GUIDE-FRONT DOOR WINDOW (FRONT)**

G.M., Olds & Buick 'N' Bodies '85/  
U-Van '90-'96  
*UNIT PACKAGE 25*

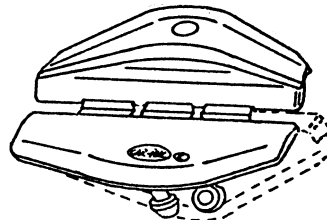

**85-5920**

Replaces: 20478733 & 22539533  
**GUIDE-FRONT DOOR WINDOW (REAR)**  
Plastic

G.M., Olds & Buick 'N' Bodies '85-'91  
'W' Bodies '92-'95, U-Van '90-'96  
*UNIT PACKAGE 25*

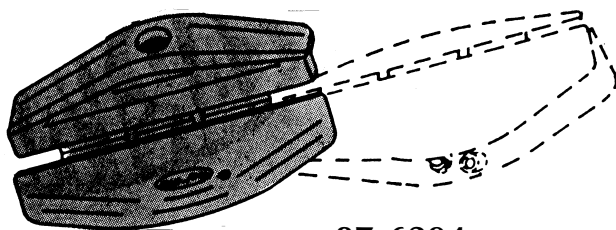

**87-6294**

Replaces: 20478732 & 20747509, 20748575  
**GUIDE-FRONT DOOR WINDOW (REAR)**

Plastic  
G.M., 'C' & 'H' Bodies '85/  
*UNIT PACKAGE 25*

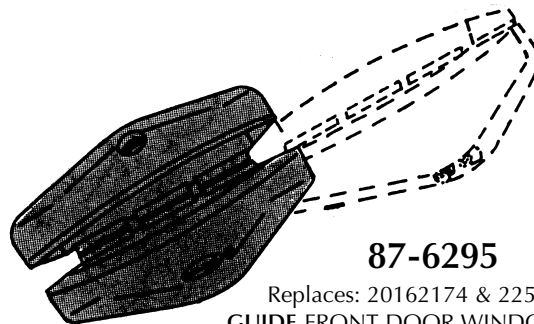

**87-6295**

Replaces: 20162174 & 22543363  
**GUIDE-FRONT DOOR WINDOW (REAR)**

Plastic  
G.M., 'J' Bodies '82/  
*UNIT PACKAGE 25*

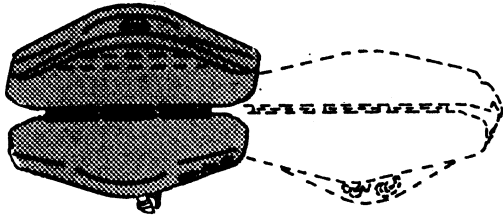

**87-6293**

Replaces: 10087223  
**GUIDE-FRONT DOOR WINDOW (REAR)**  
 Plastic  
 Chevrolet Corsica '87  
*UNIT PACKAGE 25*

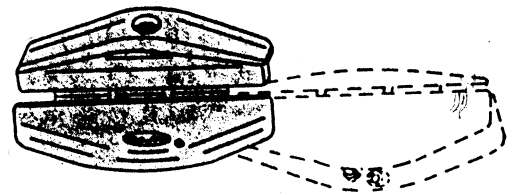

**88-6452**

Replaces: 20493450  
**GUIDE-REAR DOOR WINDOW**  
 Upper Plastic  
 Chevrolet Corsica & Beretta '87-'96  
*UNIT PACKAGE 25*

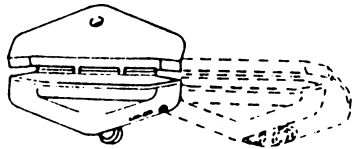

**94-7232**

Replaces: 10087223, 10103130  
**GUIDE-FRONT DOOR WINDOW (REAR)**  
 Plastic  
 Chevrolet Corsica & Beretta '87-'96  
*UNIT PACKAGE 15*

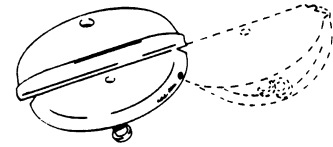

**94-7300**

Replaces: 22547112  
**GUIDE-FRONT DOOR WINDOW (REAR)**  
 Plastic  
 G.M. 'J' Bodies '82/  
*UNIT PACKAGE 25*

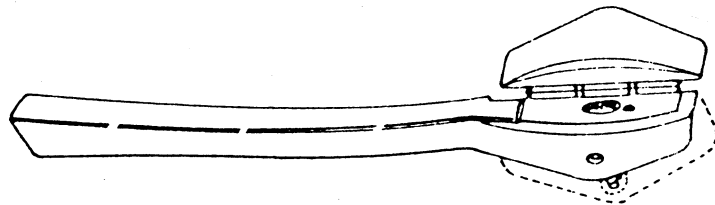

**85-5976**

Replaces: 20180140 & 22543362  
**GUIDE-FRONT DOOR GLASS (FRONT)**  
 Plastic  
 G.M. 'J' Bodies '82/  
*UNIT PACKAGE 25*

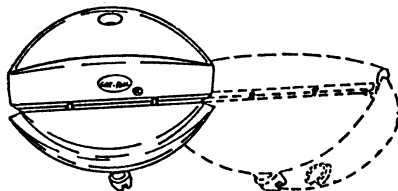

**85-5887**

Replaces: 20477850  
**GUIDE-REAR DOOR WINDOW**  
 Plastic  
 G.M. 'C' Bodies '82/  
*UNIT PACKAGE 25*

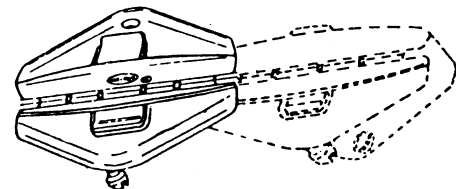

**89-6648**

Replaces: 20747508 & 20487631, 12337898  
**GUIDE-FRONT DOOR WINDOW (FRONT)**  
 Plastic  
 G.M. 'C' & 'H' Bodies '85-'93  
*UNIT PACKAGE 25*

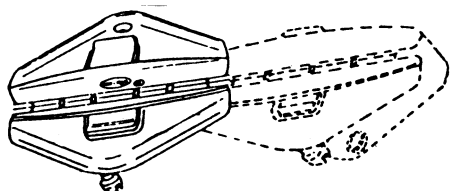
**89-6594**

Replaces: 10051034 & 10114597  
& 12338011  
**GUIDE-FRONT DOOR WINDOW**  
Plastic w/Adhesive Gasket  
G.M. 'A' Bodies '87/, 'S' Trucks '88/  
*UNIT PACKAGE 10*

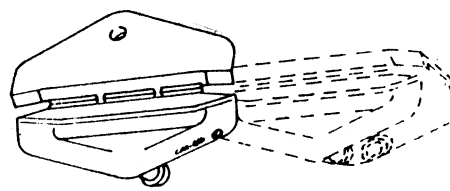
**92-7002**

Replaces: 115647709  
**GUIDE-REAR SIDE DOOR WINDOWS**  
Plastic  
G.M. S-10 Blazer 4 Door  
*UNIT PACKAGE 15*

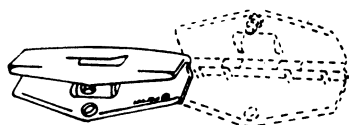
**94-7231**

Replaces: 15953718, 15985762  
**GUIDE-FRONT DOOR WINDOW**  
Plastic  
G.M. S Series Trucks '91/  
*UNIT PACKAGE 15*

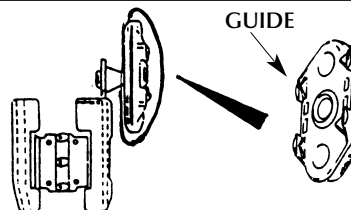
**94-7307**

Not Supplied By O.E.  
**GUIDE-FRONT DOOR WINDOW  
REGULATOR**  
Guide Only/No Stud  
Plastic  
G.M. '85/  
*UNIT PACKAGE 5*

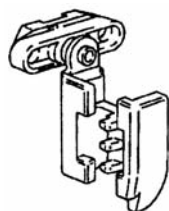
**97-7666**

Replaces: 20369894  
**GUIDE ASSEMBLY-FRONT DOOR  
WINDOW REGULATOR**  
Formerly 85-5988  
Right Side  
G.M. "C" & "N" Bodies '85/  
*UNIT PACKAGE 2*

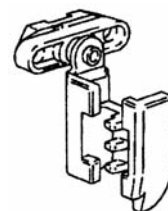
**97-7667**

Replaces: 20369895  
**GUIDE ASSEMBLY-FRONT DOOR  
WINDOW REGULATOR**  
Formerly 85-5989  
Left Side  
G.M. "C" & "N" Bodies '85/  
*UNIT PACKAGE 2*

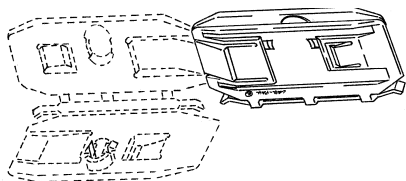
**98-7883**

Replaces: 10274778, 15786626  
**GUIDE-DOOR GLASS**  
Plastic  
G.M. "U" Vans '97/  
*UNIT PACKAGE 10*

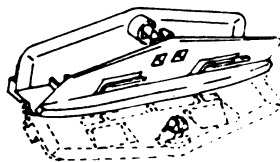
**99-8031**

Replaces: 10142872  
**GUIDE-FRONT DOOR WINDOW**  
Plastic  
Formerly 90-6758  
G.M. "A" Bodies '90/  
*UNIT PACKAGE 10*

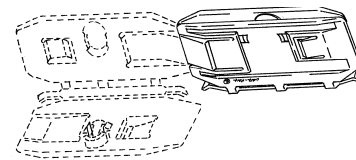
**96-7597**

Replaces: 21098967, 21170767  
**GUIDE, FRONT & REAR  
DOOR WINDOW**  
Plastic  
Saturn '96/  
*UNIT PACKAGE 5*

**TAPE CONTROLLED WINDOW REGULATOR COMPONENT PARTS**

General Motors Body Families  
'A', 'B', 'C', 'X' & Trucks 1980 - Up  
-with Tape Regulated System

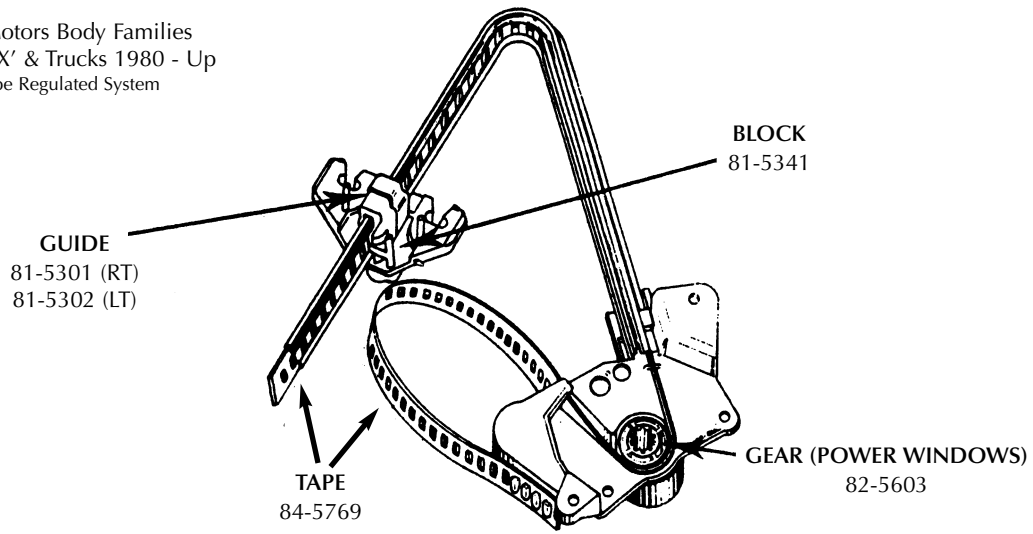

(ILLUSTRATION POWER WINDOW REGULATOR)

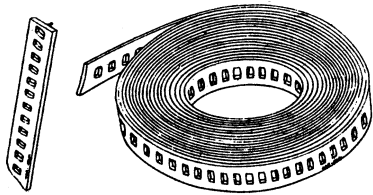

**84-5769**

Replaces: 20435391, 20161228, 20604413 & 20591996  
**TAPE-WINDOW REGULATOR ELASTOMERIC TAPE**  
Provide Strength & Flexibility Over Broad Temperature Ranged  
(20' Length in Dispenser Type Box)  
*UNIT PACKAGE 1 ROLL*

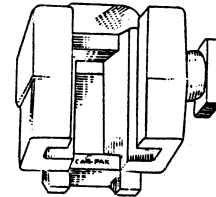

**81-5301**

Replaces: 20085730  
**GUIDE-RIGHT HAND**  
*UNIT PACKAGE 10*

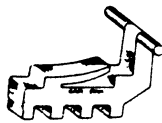

**81-5341**

Replaces: 20085729  
**BLOCK**  
*UNIT PACKAGE 25*

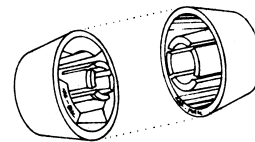

**83-5623**

Not Supplied By OEM  
**GUIDE-ON DOOR GLASS**  
Camaro & Firebird '82/  
*UNIT PACKAGE 12*

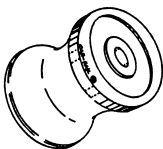

**86-6048**

Replaces: 20085501  
**WINDOW STOP-FRONT DOOR**  
(Front On Glass), Plastic  
Toronado, Riviera, Eldorado '79 - '85,  
Fiero '84/  
*UNIT PACKAGE 10*

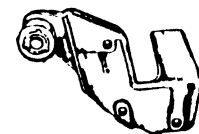

**68-3230**

Replaces: 7682226  
**PLATE-RIGHT FRONT WINDOW**  
GUIDE REAR  
G.M. Full Size Sport Sedans '67 - '68  
*UNIT PACKAGE 6*

DOOR WINDOW GUIDES CHRYSLER

WINDOW PARTS

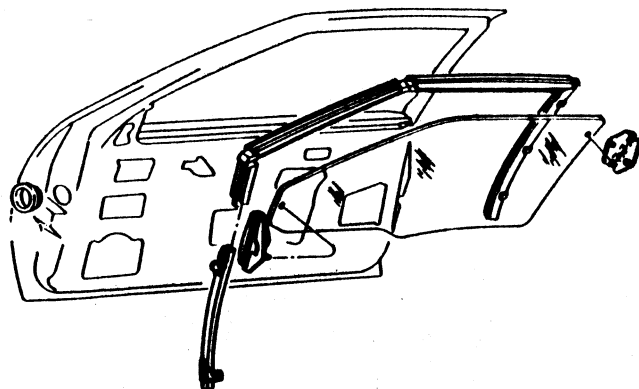

TYPICAL  
INSTALLATION

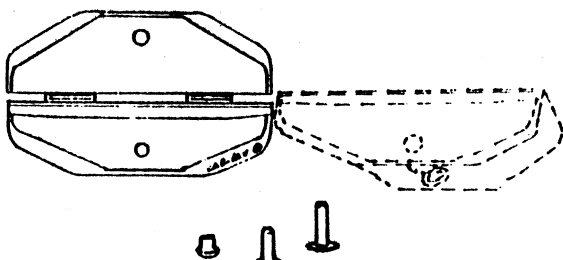

**86-6056**

Replaces: 4339372  
GUIDE-DOOR GLAS SLIDE  
w/Rivets  
Chrysler: Laron, GTS, Dodge Lancer,  
Sundance, Shadow, Acclaim Spirit '89/  
UNIT PACKAGE 25

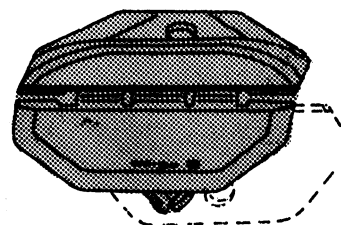

**87-6361**

Replaces: 4330292 & 4482493, 55135216  
GUIDE-DOOR GLASS  
Plastic  
Dodge Dakota Pick-up '87 /  
UNIT PACKAGE 15

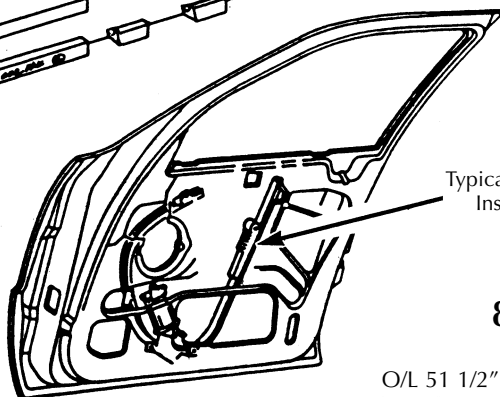
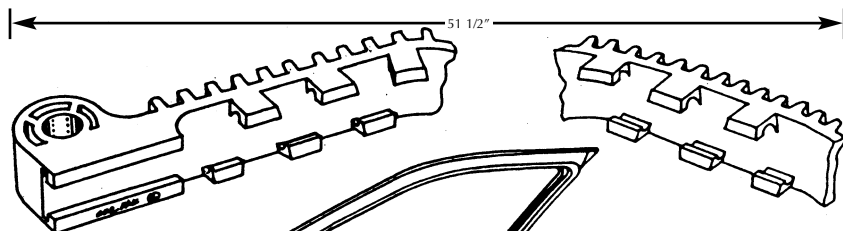

Typical Flex Rack  
Installation

**89-6656**

FLEX RACK  
O/L 51 1/2" Cut to Required Length  
Used on Flex Drive Window Regulator Assys.  
Chrysler 'C', 'E' & Mini Vans '86-'91  
UNIT PACKAGE 1



**89-6709**

CLIP-FOR GROOVED SHAFT  
FLEX RACK to WINDOW MOTOR  
Chrysler '86/  
General Purpose  
UNIT PACKAGE 50

## WINDOW REGULATOR AND CHANNEL ROLLERS & PARTS GENERAL MOTORS



**SC-3314**

**CLIP-REGULATOR ARM STUD**  
Ford, Lincoln, Mercury, Nash, Etc.  
Chrysler Products '41 - '58  
Chevrolet, GMC, Tilt Cab Trucks '60 - '64  
Internat'l Harvester Trucks '57 - '64  
*UNIT PACKAGE 50*

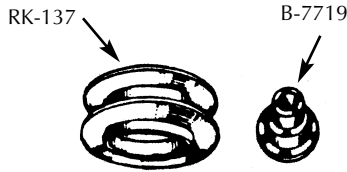

**RK-175**

**ROLLER-WINDOW REGULATOR  
ROLLER & RIVET**  
G.M. Passenger Cars Prior to '57  
G.M. Trucks Thru '65  
*UNIT PACKAGE 25*

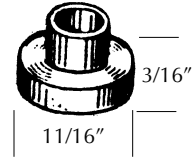

**98-7885**

Not Supplied by O.E.  
**ROLLER-WINDOW REGULATOR**  
Plastic  
Formerly RK-133  
G.M. '57 - '66, AMC '63 - '66  
*UNIT PACKAGE 15*

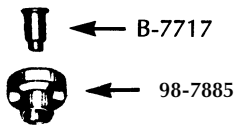

**98-7886**

Not supplied by O.E.  
**ROLLER KIT-WINDOW REGULATOR**  
Contains: 1- Roller & 1-Rivet  
Formerly RK-171  
G.M. 57/66,  
Suburban Rear Power Window  
AMC '63 - '65  
*UNIT PACKAGE 10*



**RK-137**

**ROLLER-WINDOW REGULATOR**  
(Use with B-7719)  
ID: 0.375, OD: 0.730  
Groove: 0.443, Thk: 0.328  
G.M. Most Models Prior to '57  
G.M. Trucks to '64  
*UNIT PACKAGE 25*

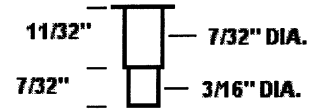

**99-8050**

**RIVET-WINDOW REGULATOR ROLLER**  
Rivet for Two Piece Roller  
G.M. Cars '57 - '66  
*UNIT PACKAGE 25*

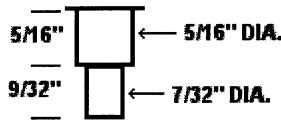

**B-7717**

**RIVET-WINDOW REGULATOR ROLLER**  
Rivet for One Piece Roller  
(Use with 98-7885)  
G.M. Cars '57 - '66  
Rambler '63 - '66  
*UNIT PACKAGE 25*

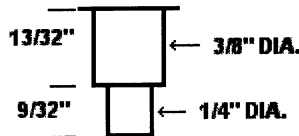

**B-7719**

**RIVET-WINDOW REGULATOR ROLLER**  
(Use with RK-137)  
G.M. Most Models Prior to '57  
G.M. Trucks to '64  
*UNIT PACKAGE 25*

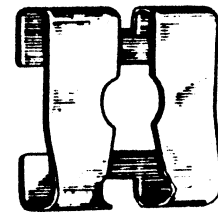

**68-3179**

Replaces: 4542715  
**CLIP-WINDOW REGULATOR  
TO CHANNEL**  
G.M. Cars '65 - '71  
*UNIT PACKAGE 50*

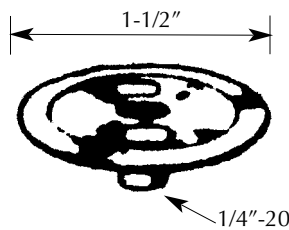

**69-3302**

**NUT-WINDOW GUIDE ROLLER**  
Plastic  
G.M. '66, Ford '70/  
*UNIT PACKAGE 25*

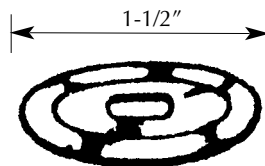

**69-3303**

**WASHER-WINDOW GUIDE ROLLER**  
Plastic  
G.M. Cars '66  
*UNIT PACKAGE 25*

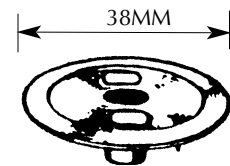

**79-5028**

Replaces: 20213450  
**NUT-STEEL. DOOR GLASS ROLLERS**  
M6-1.0 Thread Size  
G.M. Cars '79  
*UNIT PACKAGE 25*

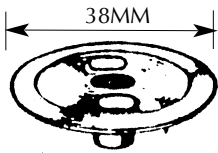

**79-5029**

Replaces: 20006849  
**NUT-STEEL DOOR GLASS ROLLER**  
 M6.3-1.0 Thread Size  
 G.M. Cars '77  
 UNIT PACKAGE 25

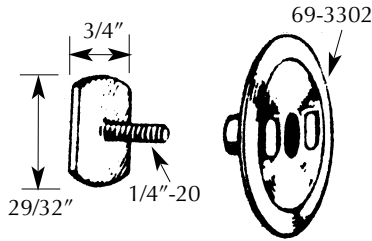

**68-3188**

**BOLT & NUT ASSEMBLY**  
 For Cars Using Bolt-on Sash  
 Method Quarter Panel  
 & Rear Door Windows  
 G.M. Compact Sport Coupes '68  
 UNIT PACKAGE 10

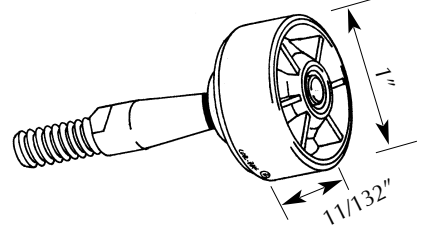

**98-7843**

Replaces: 8732651, 9812749, 9813200  
**ROLLER-FRONT & REAR WINDOW**  
 Regulator Channel, Stud: 1/4-20 x 1/2",  
 Use in place of 69-3270 & 70-3358  
 G.M. Various Models  
 (Sport Coupe & Convertible) '69 / '74  
 UNIT PACKAGE 5

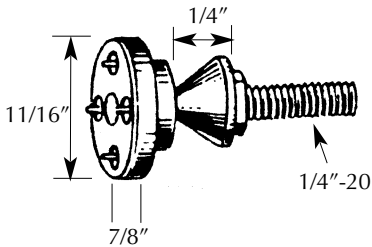

**67-3071**

**ROLLER-QUARTER WINDOW GUIDE**  
 Buick Riviera '64  
 Olds Toronado '66 - '67  
 Cadillac Eldorado '67  
 UNIT PACKAGE 12

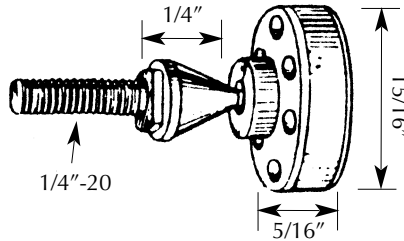

**68-3166**

**ROLLER-QUARTER WINDOW GUIDE**  
 Chevrolet & All G.M. Full Size Cars  
 Sport Coupes '66 - '67  
 Convertibles '67 - '68  
 UNIT PACKAGE 25

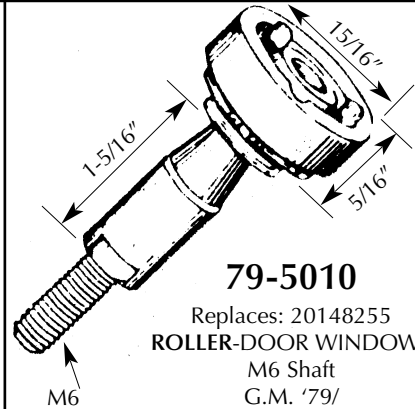

**79-5010**

Replaces: 20148255  
**ROLLER-DOOR WINDOWS**  
 M6 Shaft  
 G.M. '79/  
 UNIT PACKAGE 10

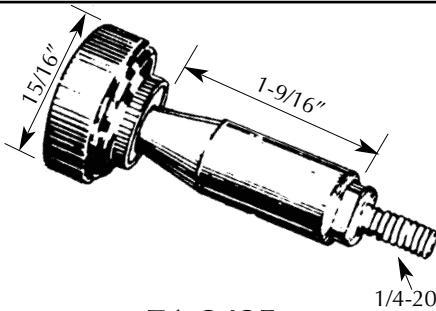

**71-3435**

Replaces: 9841756  
**ROLLER-FRONT DOOR WINDOW**  
 G.M. '71, 'B' & 'C' Models  
 UNIT PACKAGE 5

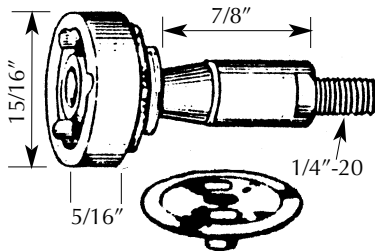

**77-4676**

Replaces: 9820729  
**ROLLER & NUT-DOOR WINDOW**  
 G.M. 69  
 UNIT PACKAGE 25

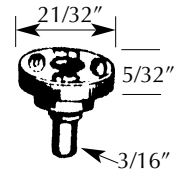

**78-4948**

Replaces: 9723881  
**ROLLER & PIN-WINDOW REGULATORS**  
 G.M. '74  
 UNIT PACKAGE 25

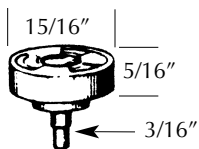

**65-1093**

Replaces: 3069189  
**ROLLER-WINDOW REGULATOR AND**  
 CHANNEL  
 G.M. '65/, S/T Truck '94/, Ford '71  
 G.M. 'J' Body '82 / '91  
 UNIT PACKAGE 25

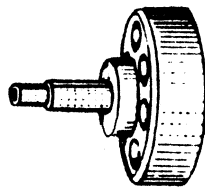

**69-3257**

Replaces: 9713250  
**ROLLER-FRONT DOOR LOWER SASH**  
 CHANNEL  
 Chevelle Sport Sedan '68  
 UNIT PACKAGE 10

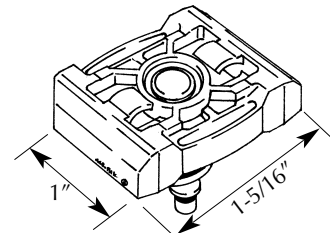

**98-7831**

Replaces: 16624405  
**GUIDE- WINDOW REGULATOR**  
 to CHANNEL  
 Fits: 1" Channel, Rivet: .194 Dia.  
 G.M. '92  
 UNIT PACKAGE 10

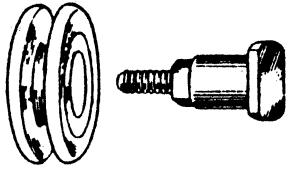

**68-3165**  
**ROLLER**  
 QUARTER WINDOW  
 FRONT GUIDE  
 Camaro, Firebird, Chevelle '67 - '68  
 All G.M. Compact Cars '68  
 UNIT PACKAGE 12

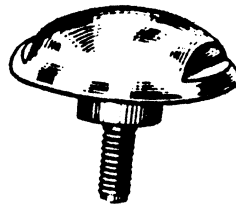

**71-3501**  
 Replaces: 7727192  
**BEARING-DOOR WINDOW GLASS**  
 (Plastic Cap)  
 Pontiac, Chevrolet '68 - '69  
 UNIT PACKAGE 10



**73-3928**  
**BEARING-DOOR WINDOW**  
 (Low Profile)  
 G.M. '68 - '69  
 UNIT PACKAGE 10



**71-3502**  
 Replaces: 7728659  
**BEARING-DOOR WINDOW GLASS**  
 (Plastic Cap)  
 Buick, Cadillac, Olds '68 - '69  
 UNIT PACKAGE 10



**71-3503**  
 Replaces: 7728658  
**BEARING-DOOR WINDOW GLASS**  
 (Plastic High Cap)  
 Chevrolet, Olds, Buick, Pontiac '68 - '69  
 UNIT PACKAGE 10

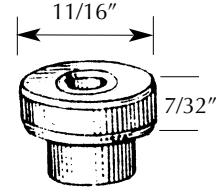

**78-4946**  
 Replaces: 9666748  
**ROLLER-WINDOW REGULATORS**  
 G.M. '72  
 UNIT PACKAGE 25

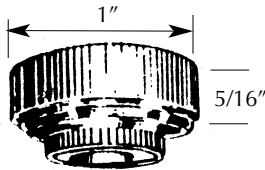

**84-5854**  
 Not Supplied By O.E.  
**ROLLER ONLY** (No Stud)  
 To Be Used On Unbroken Shaft  
 For Window Regulator &  
 Door Window Guide  
 Camaro & Firebird '82/  
 (Press on w/Channel Lock Pliers)  
 UNIT PACKAGE 10

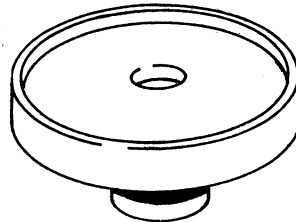

**99-8421**  
 Replaces: 20178799  
**BUSHING-WINDOW ROLLER**  
 Plastic w/Metal Insert  
 FORMERLY 91-6975  
 G.M. Various Models '79-2002  
 UNIT PACKAGE 10

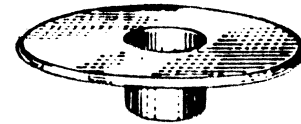

**83-5625**  
 Replaces: 20356147  
**BUSHING-WINDOW LIFT ASSEMBLY**  
 Olds '82  
 UNIT PACKAGE 25

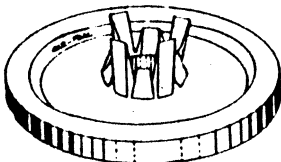

**83-5629**  
 Replaces: 20284470  
**BUSHING-FRONT & REAR**  
**DOOR WINDOW GLASS**  
 G.M. '82/  
 UNIT PACKAGE 25

**SEE**  
**[www.carpak.com](http://www.carpak.com)**  
**FOR UPDATED**  
**O.E. CROSS-REFERENCES**

GENERAL USE WINDOW REGULATOR CHANNEL ROLLERS

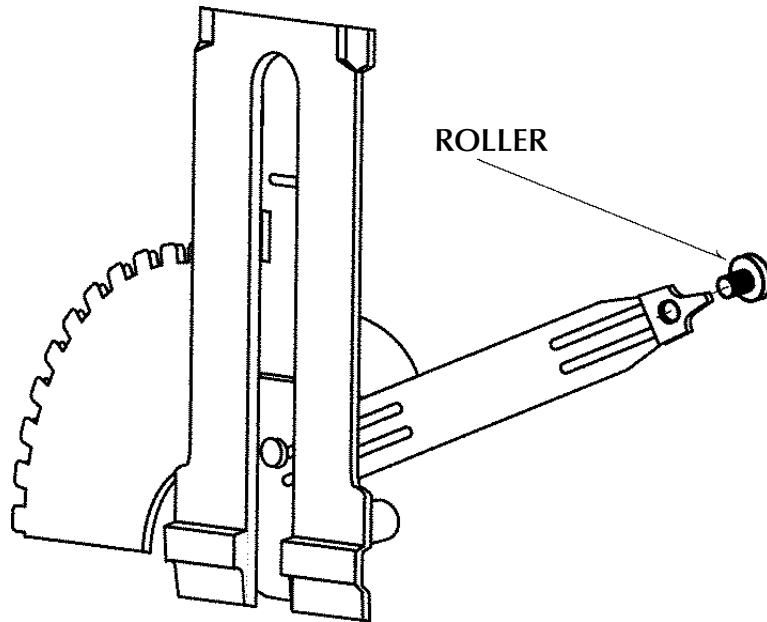

TYPICAL

WINDOW PARTS

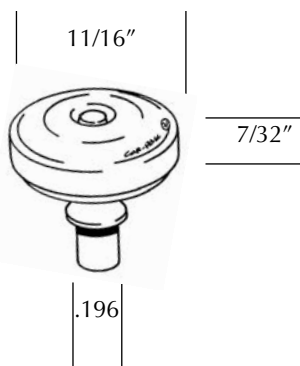

**98-7818**

Not Supplied By O.E.  
**ROLLER-WINDOW**  
 REGULATOR CHANNEL  
 Stud Dia: .196, Panel Tkns: .125,  
 Roller Dia: 11/16",  
 Channel Depth: 7/32"  
 G.M., General Use  
 UNIT PACKAGE 5

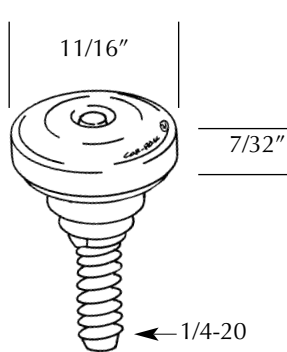

**98-7819**

Not Supplied By O.E.  
**ROLLER-WINDOW**  
 REGULATOR CHANNEL  
 Stud: 1/4-20 x 1/2", Roller Dia: 11/16",  
 Channel Depth 7/32"  
 G.M. Compacts & General Use  
 UNIT PACKAGE 5

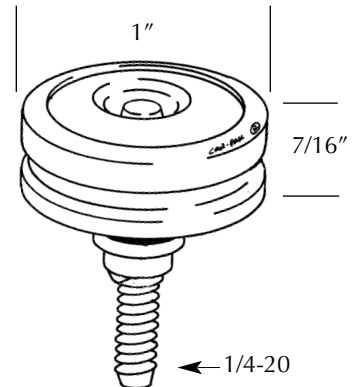

**98-7820**

Not Supplied By O.E.  
**ROLLER-WINDOW**  
 REGULATOR CHANNEL  
 Stud: 1/4-20 X 1/2"  
 Roller Dia: 1" w/Groove,  
 Roller Thickness: 7/16"  
 G.M., Various Models '67/  
 UNIT PACKAGE 5

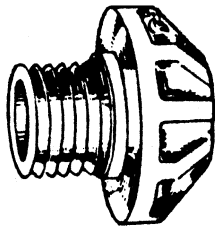

**71-3433**

Replaces: 9839949  
**BUSHING-FRONT & REAR DOOR  
 LOWER SASH PLATE**  
 G.M. Full Size 4 Door Hardtops '71 - '72  
*UNIT PACKAGE 10*

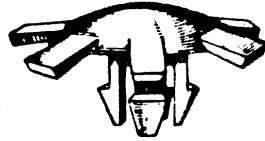

**72-3601**

**RETAINER-DOOR GLASS TO CHANNEL**  
 (Low Profile), Black  
 G.M. '72  
*UNIT PACKAGE 10*

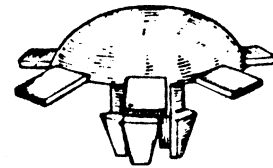

**72-3602**

**RETAINER-DOOR GLASS TO CHANNEL**  
 (Medium Profile), Clear Plastic  
 G.M. '72  
*UNIT PACKAGE 10*

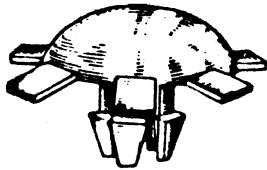

**73-3814**

Replaces: 9834130  
**RETAINER-DOOR GLASS TO CHANNEL**  
 G.M. '71 - '73  
*UNIT PACKAGE 10*

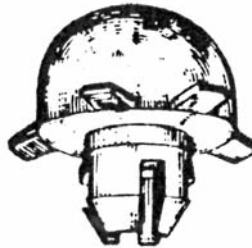

**71-3442**

Replaces: 9784347  
**RETAINER-DOOR GLASS TO CHANNEL**  
 G.M. '71 - '73  
*UNIT PACKAGE 10*

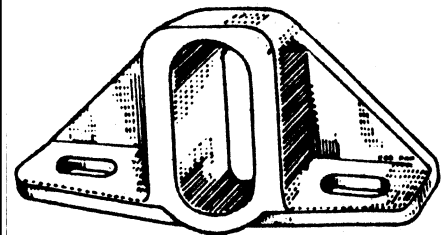

**74-3980**

Not Supplied By OEM  
**BUSHING-DOOR GUIDE**  
 G.M. '73 - '74  
*UNIT PACKAGE 6*

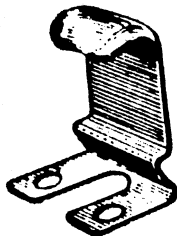

**71-3439**

Replaces: 8758358  
**CLIP-WINDOW BLOW OUT PREVENTION**  
 1 1/8" O/L  
 G.M. Cars  
*UNIT PACKAGE 10*

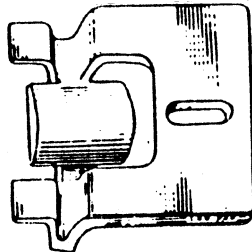

**77-4595**

Replaces: 3068866  
**CLIP-REVEAL MOULDING**  
 G.M. '78  
*UNIT PACKAGE 25*



**75-4169**

Replaces: 1657696  
**CLIP-QUARTER WINDOW GLASS  
 RETAINER**  
 G.M. '75 - '76  
*UNIT PACKAGE 50*

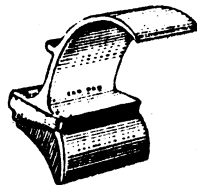

**75-4171**

Replaces: 1698296  
**CLIP-QUARTER WINDOW GLASS  
 RETAINER**  
 G.M. '75 - '76  
*UNIT PACKAGE 50*

**75-4170**

Replaces: 1690550  
**CLIP-QUARTER WINDOW GLASS  
 RETAINER**  
 G.M. '75 - '76  
*UNIT PACKAGE 50*

**DOOR WINDOW BRACKET - FORD & IMPORTS**

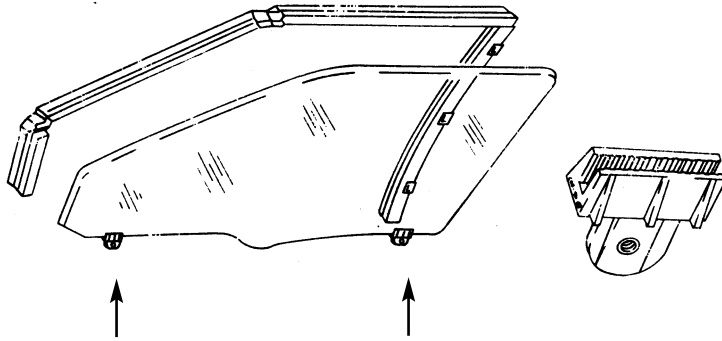

**93-7102**

Replaces: 69951-12180  
**BRACKET DOOR WINDOWS**  
 Plastic w/M6-1.0 Threaded, Steel Insert  
 Can Be Used On Import and Various  
 Domestic Vehicles  
 UNIT PACKAGE 5

WINDOW PARTS

**FORD**



**RK-100**

**ROLLER-WINDOW REGULATOR ARM**  
 Ford, Lincoln, Mercury, '52 - '58  
 Ford Trucks '52 - '65  
 UNIT PACKAGE 25



**RK-128**

Replaces: C0AB-6423240  
**ROLLER-WINDOW REGULATOR**  
 Ford, Mercury '65 - '70, Edsel '59 - '65  
 UNIT PACKAGE 50  
**J01601**  
 UNIT PACKAGE 25

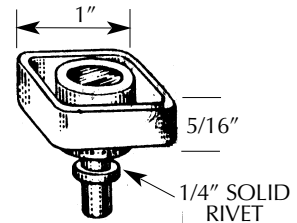

**73-3853**

Replaces: D4SZ-75234B36-A &  
 E9TZ1023240A  
**ROLLER-WINDOW REGULATOR**  
 T-Bird '74, Bronco '89/  
 UNIT PACKAGE 25

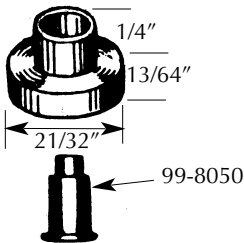

**99-8052**

**ROLLER (SMALL) & RIVET**  
**QUARTER WINDOW LOWER**  
**SASH CHANNEL**  
 Ford, Mercury,  
 Convertible and Hardtop '66  
 UNIT PACKAGE 5

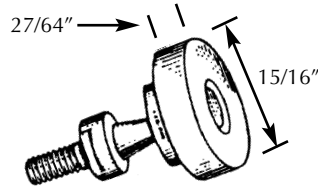

**98-7906**

Not Supplied By O.E.  
**ROLLER-WINDOW REGULATOR**  
**CHANNEL**  
 Stud: 1/4-20 X 7/16", Roller: 15/16 x 27/64"  
 Formerly 77-4528  
 Ford '74/  
 UNIT PACKAGE 10

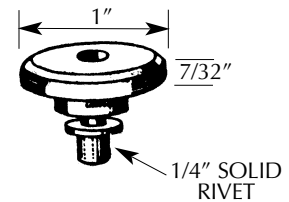

**75-4229**

Replaces: D20Z-6530436-A  
**ROLLER-QUARTER WINDOW**  
 Ford Products '72  
 UNIT PACKAGE 12

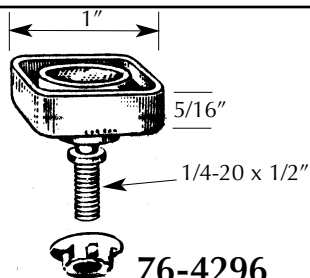

**76-4296**

Replaces: D6AZ-5323240-A  
**ROLLER & NUT-WINDOW GUIDE**  
 Ford Products '74/, Ford Pick-up '90/  
 UNIT PACKAGE 10

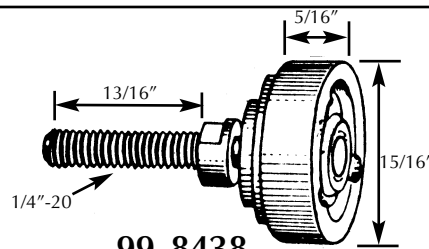

**99-8438**

Not Supplied By O.E.  
**ROLLER-WINDOW REGULATOR**  
 Formerly 71-3551  
 Ford Products '72  
 UNIT PACKAGE 5

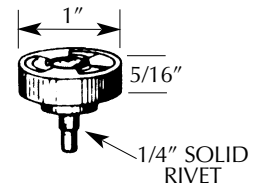

**71-3431**

**ROLLER-DOOR WINDOW**  
 Ford Products '71  
 UNIT PACKAGE 10

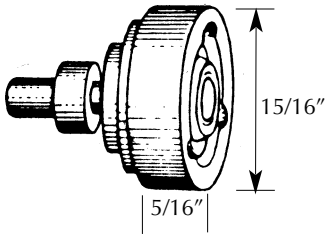

**71-3552**  
**ROLLER-WINDOW REGULATOR**  
 Ford '72  
 UNIT PACKAGE 10

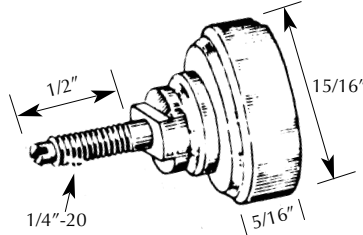

**99-8439**  
 Replaces: D1AZ-57270A54-AB  
**ROLLER- QUARTER WINDOW**  
 Formerly 71-3432  
 Ford Products '71  
 UNIT PACKAGE 5

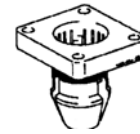

**97-7759**  
 Not Supplied By O.E.  
**GROMMET NUT-WINDOW**  
 Regulator To Door Glass  
 Hole: 1/2", Head: 3/4" Sq. X 3/16" Thick  
 Use 3/8-16 X 3/4" Grade 8 Cap Screw  
 (Jobber No 5272)  
 Ford Contour & Mystique '95/  
 UNIT PACKAGE 25

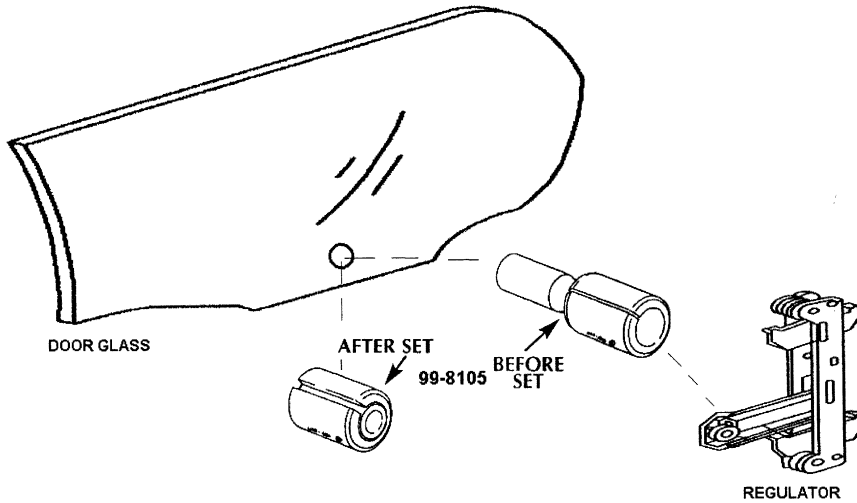

**99-8105**  
 Replaces: XW4Z-54234A44-AA  
**SPACER-DOOR GLASS BRACKET ATTACHING**  
 Plastic  
 2 Step Bushing. When Compressed  
 Engages Glass For A Secure Attachment  
 Ford Focus & Lincoln LS 2000/  
 UNIT PACKAGE 10



**CS10116**  
**COIL SPRING-WINDOW REGULATOR**  
 (Use with RK-100)  
 Ford, Lincoln, Mercury, '52 - '58  
 Ford Trucks '52 - '66  
 UNIT PACKAGE 100



**WC-2051**  
**RETAINING CLIP-WINDOW REGULATOR**  
 ROLLER  
 (Use with RK-100)  
 Ford, Lincoln, Mercury '52 - '66  
 UNIT PACKAGE 100

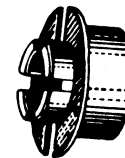

**71-3530**  
 Replaces: D1AZ-65297A-22AA  
**GUIDE-QUARTER WINDOW**  
 Nylon, 2 Door Hardtops  
 Ford '71- '72  
 UNIT PACKAGE 25

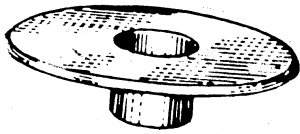

**69-3289**

Replaces: C9ZZ-65232580B  
**GROMMET-WINDOW**  
 Nylon  
 Mustang, Maverick '69 - '70  
*UNIT PACKAGE 25*

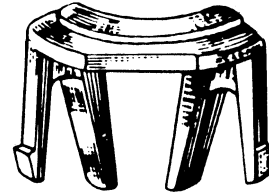

**72-3768**

Replaces: D1ZZ-65223A58  
**GUIDE-DOOR WINDOW LOWER**  
 Anti-Rattle  
 Mustang '71  
*UNIT PACKAGE 25*



**73-3842**

Not Supplied By O.E.  
**RIVET-DOOR GLASS ATTACHING PARTS**  
 (Use with 73-3792)  
 Ford Products '73  
*UNIT PACKAGE 50*

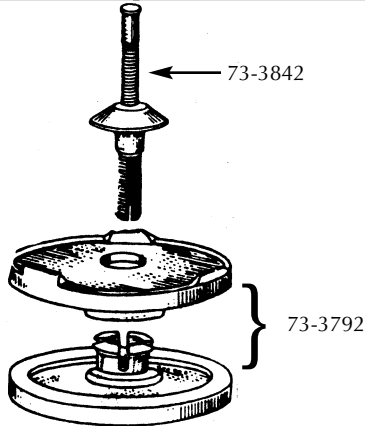

**79-5008**

Not Supplied By O.E.  
**DOOR GLASS TO CHANNEL ATTACHING KIT**  
 For Use On Thinner Glass  
 Ford Products '78  
*UNIT PACKAGE 10*

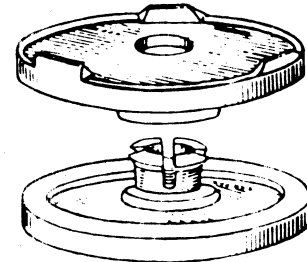

**73-3792**

Not Supplied By O.E.  
**ROLLER-DOOR GLASS TO CHANNEL ATTACHING KIT**  
 Ford Products '73/  
*UNIT PACKAGE 10*

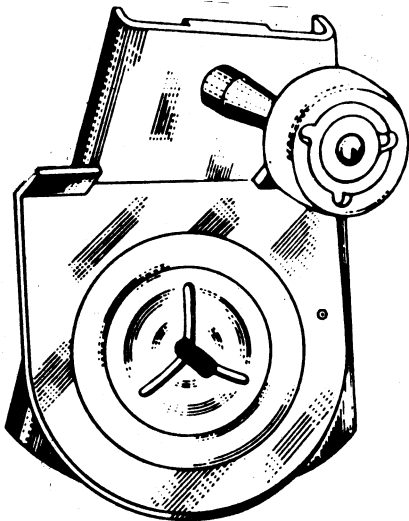

**72-3689**

Replaces: D3AZ-5726106-A  
**ROLLER & SLIDE ASSEMBLY**  
 WINDOW TRACK  
 Ford '73  
*UNIT PACKAGE 5*

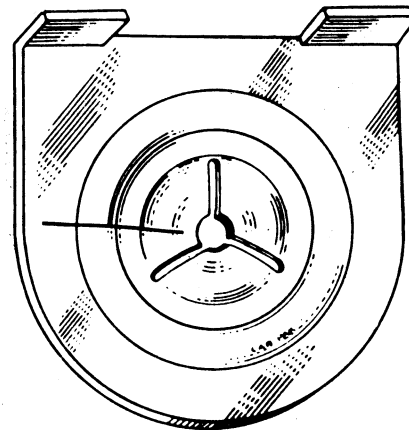

**72-3691**

Not Supplied By OEM  
**SLIDE-WINDOW TRACK**  
 Ford '73  
*UNIT PACKAGE 10*

**CHRYSLER / AMC**

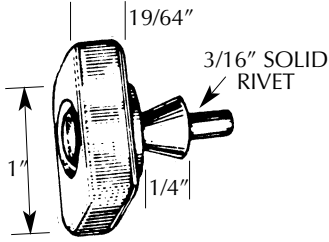

**72-3565**

Not Available From OEM  
**SLIDE-WINDOW REGULATOR**  
 MANUAL w/STUD  
 Chrysler '72  
*UNIT PACKAGE 10*

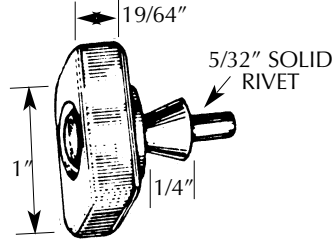

**72-3570**

**SLIDE-WINDOW REGULATOR**  
 POWER w/STUD  
 Chrysler '72  
*UNIT PACKAGE 10*

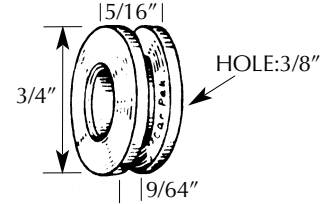

**72-3604**

Replaces: 1697607  
**ROLLER-QUARTER WINDOW**  
 REGULATOR  
 Chrysler '65 - '67, '70 - '72  
 Plymouth Barracuda '64  
*UNIT PACKAGE 50*

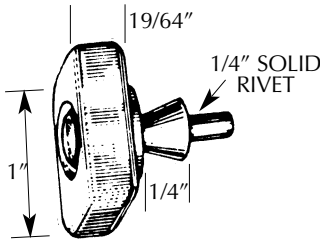

**76-4268**

Replaces: 3454363  
**SLIDE-WINDOW REGULATOR, TAILGATE**  
 Chrysler Products Station Wagons  
*UNIT PACKAGE 10*

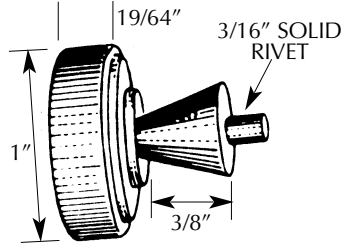

**72-3694**

Replaces: 396644  
**ROLLER-WINDOW TRACK**  
 Chrysler Products '73  
*UNIT PACKAGE 10*

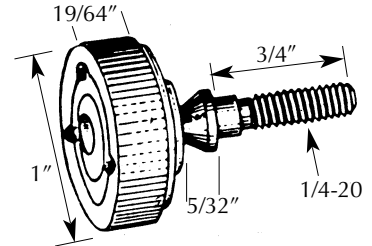

**72-3695**

Replaces: 2696726  
**ROLLER-WINDOW TRACK**  
 Chrysler Products '73  
*UNIT PACKAGE 10*

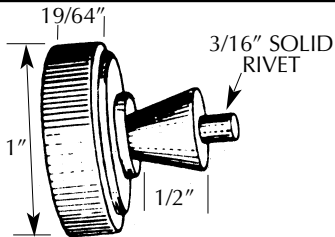

**72-3693**

Replaces: 3966568  
**ROLLER-WINDOW TRACK**  
 Chrysler Products '73  
*UNIT PACKAGE 10*

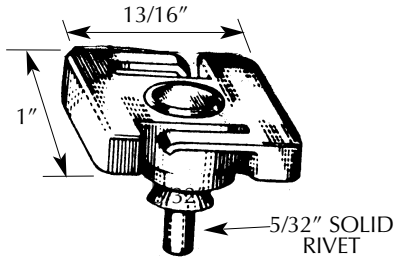

**71-3545**

**SLIDE-WINDOW REGULATOR**  
 Chrysler Products '70 - '71  
*UNIT PACKAGE 10*

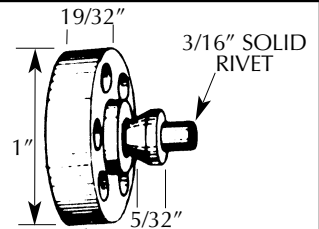

**71-3500**

Replaces: 3670149  
**ROLLER-WINDOW REGULATOR**  
 Chrysler '72 - '76  
*UNIT PACKAGE 10*

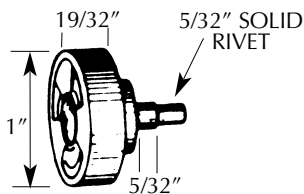

**71-3546**

**ROLLER-POWER WINDOW**  
 REGULATOR  
 Chrysler '72  
*UNIT PACKAGE 10*

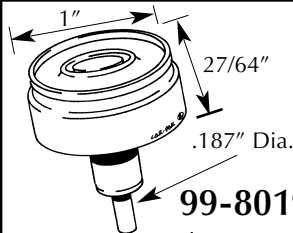

**99-8019**

Replaces: 4339301  
**ROLLER-WINDOW REGULATOR**  
 Channel  
 Stud Dia.: .187, Roller: 1" x 27/64"  
 Chrysler 'K' 'LH' Cirrus, Stratus, Breeze  
 Dodge 'B' Van &  
 Full Size Pick Ups '84-2007  
*UNIT PACKAGE 5*

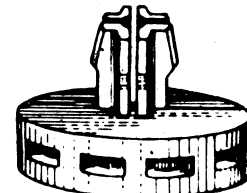

**69-3330**

Replaces: 2861680  
**RETAINER-DOOR GLASS TO**  
 TRACK & GUIDE  
 Chrysler Products 4 Door  
 Hardtop '69 - '70  
*UNIT PACKAGE 10*

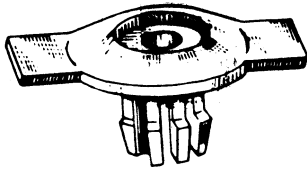

**71-3512**  
 Replaces: 4003707  
**GUIDE-FRONT DOOR WINDOW**  
**REGULATOR, REAR**  
 American Motors '69 - '72  
*UNIT PACKAGE 10*

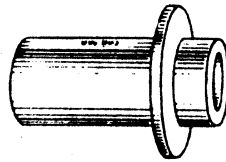

**72-3677**  
 Replaces: 3582011  
**STOP-FRONT DOOR GLASS**  
 Up Position on Glass Power Windows  
 Chrysler Products Station Wagons '72 - '73  
*UNIT PACKAGE 25*

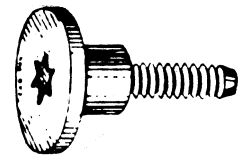

**76-4257**  
 Replaces: 4004741  
**BOLT-SHOULDER TO WINDOW**  
**REGULATOR TO DOOR GLASS**  
 1/4-20 w/Lock Strip  
 American Motors, Hornet,  
 Gremlin, Pacer '73  
*UNIT PACKAGE 25*

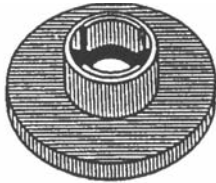

**J04308**  
 Replaces: 118152  
**RETAINER-LOWER WINDOW CHANNEL**  
 Screw: 1/4"-20  
 Use with 4309  
 Chrysler  
*UNIT PACKAGE 25*

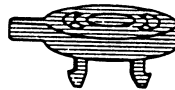

**J04309**  
 Replaces: 118153  
**RETAINER-LOWER WINDOW CHANNEL**  
**TO GLASS**  
 Use with 4308  
 Chrysler  
*UNIT PACKAGE 25*

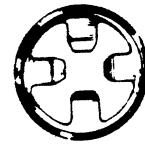

**SC-3315 (J01723)**  
**FASTENER-WINDOW REGULATOR**  
**ARM STUD**  
 Chrysler Products  
*UNIT PACKAGE 50*

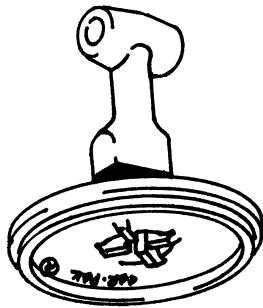

STUD ATTACHES TO  
 BASE OF ADAPTER

ADAPTER  
 ATTACHES  
 TO STUD  
 GLASS

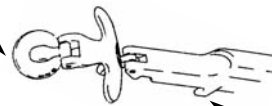

MANUAL LATCH  
 ASSEMBLY

**96-7566**  
 Not Supplied By O.E.  
**ADAPTER** for Quarter Glass Manual Latch  
 Glass Supplied w/Adapter for Power Latch Only  
 Kit Contains Adapter & Pin in Poly Bag  
 Chrysler Minivan '96/  
*UNIT PACKAGE 5*

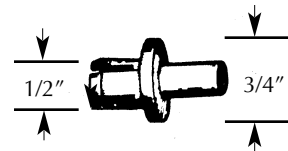

**B-7733**  
 Replaces: 6023695  
**RIVET-TAILGATE GLASS CHANNEL**  
 Plastic  
 Plymouth, Dodge '63  
*UNIT PACKAGE 100*

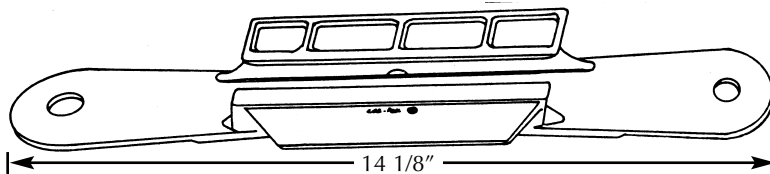

**88-6468**  
 Replaces: 4396736  
**LIFT-CHANNEL DOOR GLASS**  
**FRONT DOOR**  
 Plastic  
 Chrysler Products, Shadow, Sundance 2 Door '87  
*UNIT PACKAGE 1*

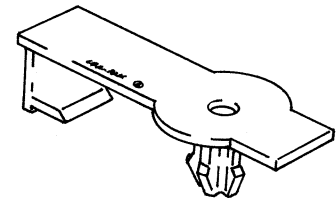

**99-8065**  
 Replaces: 5008055AA  
**GROMMET-WINDOW TO REGULATOR**  
 Plastic  
 Hole: M12.7, Glass Thickness 3.5MM  
 Screw M6.3  
 Chrysler Neon 2000  
*UNIT PACKAGE 15*



**79-5057**  
 Replaces: 0152861  
**SPACER-WINDSHIELD GARNISH  
 MOULDING UPPER**  
 1/4" Head Height  
 No. 8 Screw Size  
 Chrysler Products '79  
*UNIT PACKAGE 50*



**79-5058**  
**SPACER-WINDSHIELD**  
 3/8" Head Height  
 No. 8 Screw Size  
 Chrysler Products '78  
*UNIT PACKAGE 50*



**79-5059**  
 Replaces: 0152863  
**SPACER-REAR GLASS GARNISH  
 MOULDING**  
 1/2" Head Height  
 No. 8 Screw Size  
 Chrysler Products '78  
*UNIT PACKAGE 50*

**WINDOW LIFT MOTOR**

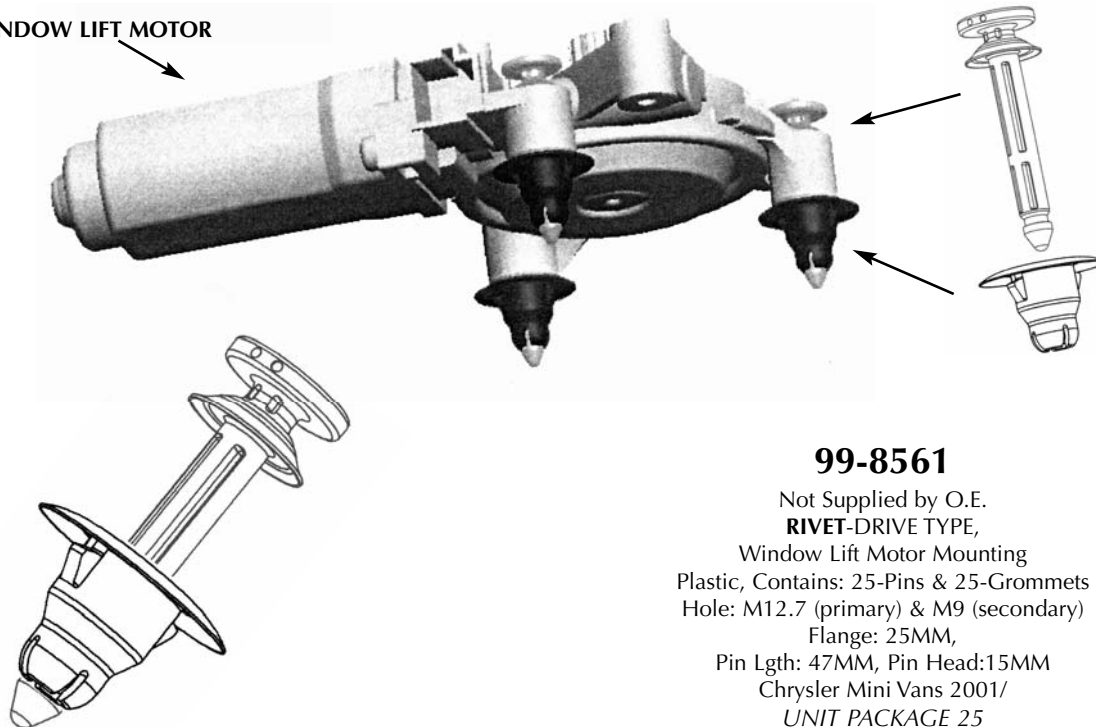

**99-8561**

Not Supplied by O.E.  
**RIVET-DRIVE TYPE,**  
 Window Lift Motor Mounting  
 Plastic, Contains: 25-Pins & 25-Grommets  
 Hole: M12.7 (primary) & M9 (secondary)  
 Flange: 25MM,  
 Pin Lgth: 47MM, Pin Head:15MM  
 Chrysler Mini Vans 2001/  
*UNIT PACKAGE 25*



## VENT WINDOW PARTS

### UPPER PIVOT REPAIR KITS

**UVP-211R(RIGHT)  
UVP-211L(LEFT)**  
UPPER PIVOT VENT WINDOW KIT  
(ON GLASS)

Each Kit Contains:  
1 Pivot; 2-Rubber Washer; 1-Plate; 1-Screw  
Dodge, Plymouth Early Models Cars/  
*UNIT PACKAGE 12 KITS*

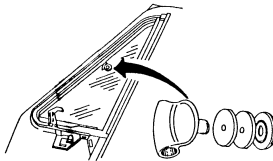

**UVP-212R(RIGHT)  
UVP-212L(LEFT)**  
UPPER PIVOT VENT WINDOW KIT  
(ON GLASS)

Each Kit Contains:  
1 Pivot; 2-Rubber Washer; 1-Plate; 1-Screw  
Dodge, Plymouth Vans and Trucks 1960/  
*UNIT PACKAGE 12 KITS*

**VLK-7**  
VENT LATCH KIT

Ford, Mercury & Lincoln '50 - '56  
Passenger Cars, Ford Truck '50 - '63  
International Trucks '55 - '57  
Rambler '58 - '62, Checker Cab '56 -'67  
*UNIT PACKAGE 100*

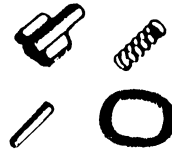

**VHB 105R (RIGHT) / VHB 105L (LEFT)**

VENT WINDOW BRACKET  
Ford Cars '55 - '56  
Ford Trucks '56 -'60  
*UNIT PACKAGE 12*



**67-3126**

Replaces: 9703379  
**TEE SHAFT CLIP**  
VENT WINDOW REGULATOR  
G.M. Cars '65/  
*UNIT PACKAGE 25*

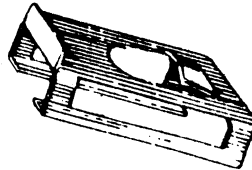

**67-3127**

Replaces: 4155278  
**SPRING CLIP**  
VENT WINDOW REGULATOR  
G.M. Cars '53/  
*UNIT PACKAGE 25*

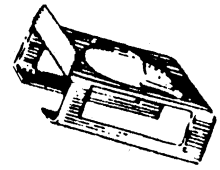

**70-3352**  
LOWER VENTILATOR WINDOW PIVOT  
RIGHT & LEFT  
International Harvester Scout '68/  
*UNIT PACKAGE 12*



**71-3559**  
VENTILATOR WINDOW  
HANDLE  
BRACKET & SHAFT, R.H.  
Chevrolet Nova '71/  
*UNIT PACKAGE 12*



**70-3356**  
UPPER VENTILATOR PIVOT  
ON RETAINER  
RIGHT HAND  
Ford & Mercury '70/  
*UNIT PACKAGE 12*

**70-3357**  
UPPER VENTILATOR PIVOT  
ON RETAINER  
LEFT HAND  
Ford & Mercury '70/  
*UNIT PACKAGE 12*

### WEATHERSTRIP

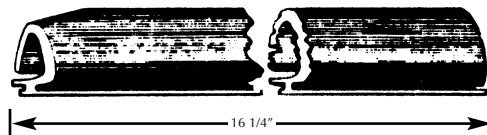

**68-2047**  
WEATHERSTRIP  
QUARTER WINDOW DIVISION BAR  
Left Hand  
2 & 4 Door Hardtops  
G.M. '64 - '69 (Cut to Size)  
*UNIT PACKAGE 6*

**68-2048**  
WEATHERSTRIP  
QUARTER WINDOW DIVISION BAR  
Right Hand  
2 & 4 Door Hardtops  
G.M. '64 - '69 (Cut to Size)  
*UNIT PACKAGE 6*

WINDOW PARTS

## WINDOW CHANNEL

Channels are made of Steel almost twice as thick as the Original Part.  
The Channels are Zinc plated to retard rust.

• **Universal**

Can be Cut to Length for any Car,  
Any Model Particularly Useful for  
Jobs for Which No Channel is  
Available

• **All Steel**

• **Plated**

### Universal Bottom Channel

Available in 2 Lengths

#### UC-100

Universal Channel  
8-foot Lengths  
*UNIT PACKAGE 1*  
(50 pcs.)

#### 65-1139

Universal Channel  
4-foot Lengths  
*UNIT PACKAGE 1*  
(50 pcs.)

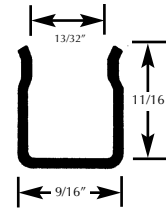

### COMMON CROSS SECTION



#### 73-3917

Not Supplied by OEM  
**LOWER SASH CHANNEL, TAILGATE**  
48" Length  
Chevrolet & G.M.C. Jimmy & Blazer '73  
*UNIT PACKAGE 6*

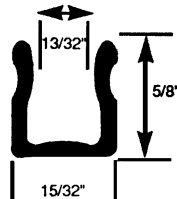

#### 73-3922

**LOWER SASH CHANNEL, TAILGATE**  
59" Length  
Chevrolet & G.M.C. Suburban '73  
*UNIT PACKAGE 6*

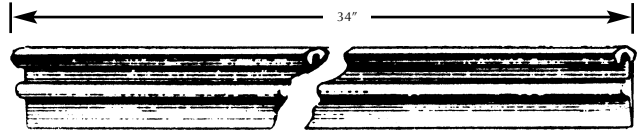
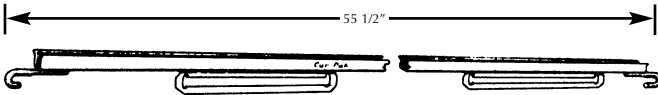

#### 72-3605

Replaces: 341865-C1  
**TAILGATE BOTTOM CHANNEL**  
55 1/2" Length  
International Harvester '69 - '72  
Travel All  
*UNIT PACKAGE 6*

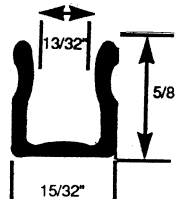

#### 67-3085

**QUARTER WINDOW RETAINER**  
34" Length  
Sealing Strip  
Plastic  
G.M. Cars w/bolt-on Windows '65  
*UNIT PACKAGE 12*

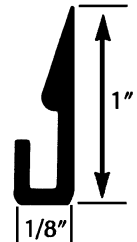

## WINDOW REGULATOR REPAIR PARTS



#### B-7723

**RIVET (solid)-WINDOW REGULATOR  
ARM**  
All G.M. Window Regulators  
Rivet: 1/4", Head: 1/2"  
Stem Lgth.: 0.390, O/L: 0.475  
General Purpose  
*UNIT PACKAGE 50*



#### 65-1055

**HOUSING-WINDOW REGULATOR  
CLUTCH GEAR**  
Chevrolet Truck '61 - '65,  
General Use, Other G.M. Cars & Trucks  
*UNIT PACKAGE 12*

## WINDOW SWITCHES & PARTS: AUTOMATIC WINDOW SWITCHES



**82-5492**

Replaces: 1734573  
**NUT-TWIST OFF POWER WINDOW**  
 G.M. Products  
*UNIT PACKAGE 25*

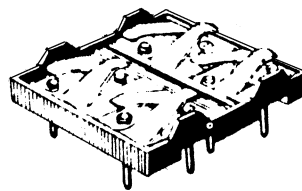

**SW-305**

Replaces: 5712825  
**SWITCH-AUTOMATIC WINDOW SWITCH 4-WAY**  
 Cadillac '61 - '62, Buick (Some Models) '61 - '62  
*UNIT PACKAGE 6*

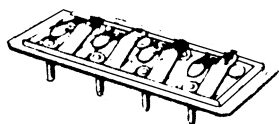

**66-3043**

**SWITCH-AUTOMATIC WINDOW SWITCH**  
 4-WAY, IN LINE  
 G.M. '65 - '72  
*UNIT PACKAGE 6*

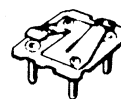

**66-3042**

**SWITCH-AUTOMATIC WINDOW SWITCH**  
 SINGLE  
 G.M. '65 - '72  
*UNIT PACKAGE 12*

WINDOW PARTS



[www.carpak.com](http://www.carpak.com)

# CAR-PAK

®

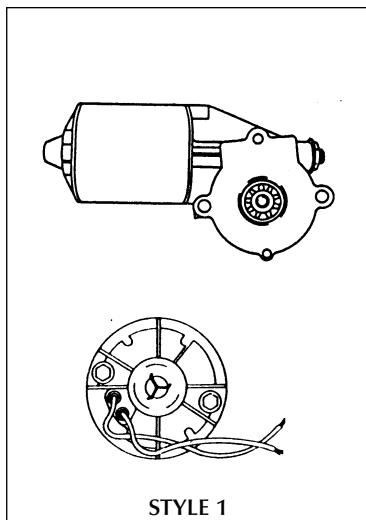

STYLE 1

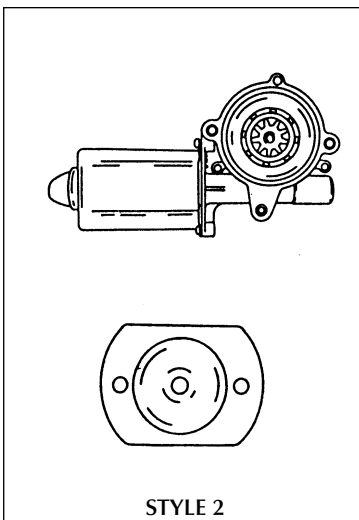

STYLE 2

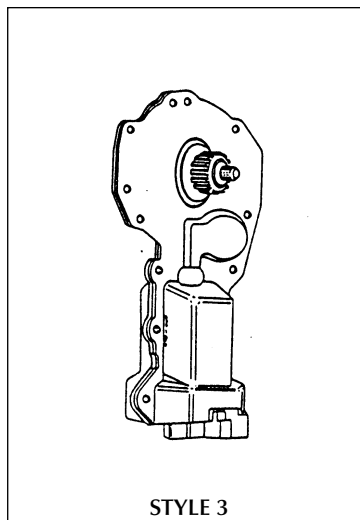

STYLE 3

## REPLACEMENT POWER WINDOW LIFT MOTORS FOR FORD & GENERAL MOTOR VEHICLES

### APPLICATION FOR WINDOW LIFT MOTOR NUMBERS:

93-7107  
93-7108  
93-7109  
93-7110  
93-7111

93-7112  
93-7113  
93-7114  
93-7115  
93-7117

93-7118  
93-7119  
93-7121  
93-7122  
93-7123

YEAR	MAKE / MODEL	STYLE	RIGHT FRONT	LEFT FRONT	RIGHT REAR	LEFT REAR	GEAR	TORQ PIN
<b>BUICK</b>								
<b>Century</b>								
96-82	All	3	93-7107	93-7107	93-7107	93-7107	—	—
81-79	All	3	93-7107	93-7107	—	—	—	—
Electra, Estate Wagon, LeSabre, Park Ave.								
90-91	LeSabre 4 Dr	3	93-7107	93-7107	—	—	—	—
90	Electra	3	93-7107	93-7107	—	—	—	—
88-90	Estate Wagon	3	93-7107	93-7107	93-7107	93-7107	—	—
88-89	All—Exc. Estate Wagon	3	93-7107	93-7107	—	—	—	—
80	All	3	93-7107	93-7107	93-7107	93-7107	—	—
<b>Regal</b>								
79-87	All	3	93-7107	93-7107	—	—	—	—
<b>Riviera &amp; Reatta</b>								
80-93	All	3	93-7107	93-7107	—	—	—	—
79	w/4 Hole Mount	3	93-7107	93-7107	—	—	—	—
<b>Skyhawk, Skylark, Somerset, Apollo &amp; Special</b>								
80-98	All	3	93-7107	93-7107	93-7107	93-7107	—	—
<b>CADILLAC</b>								
<b>Brougham, Commercial, Concours, DeVille, &amp; Fleetwood</b>								
90-92	RWD	3	93-7107	93-7107	93-7107	93-7107	—	—
89	FWD	3	93-7107	93-7107	—	—	—	—
	RWD	3	93-7107	93-7107	93-7107	93-7107	—	—
80-88	All	3	93-7107	93-7107	93-7107	93-7107	—	—
<b>Cimarron</b>								
82-88	All	3	93-7107	93-7107	93-7107	93-7107	—	—
<b>Eldorado, Seville</b>								
80-91	All	3	93-7107	93-7107	93-7107	93-7107	—	—
79	Eldorado—w/4 Hole Mount	3	93-7107	93-7107	—	—	—	—
<b>CHEVROLET</b>								
<b>Belair, Biscayne, Caprice &amp; Impala</b>								
80-90	All	3	93-7107	93-7101	93-7107	93-7107	—	—
<b>Camaro</b>								
82-92	All	3	93-7107	93-7107	—	—	—	—
<b>Cavalier</b>								
82-99	All	3	93-7107	93-7107	93-7107	93-7107	—	—

WINDOW PARTS



YEAR	MAKE / MODEL	STYLE	RIGHT FRONT	LEFT FRONT	RIGHT REAR	LEFT REAR	GEAR	TORQ PIN
82-90	All <b>Celebrity</b>	3	93-7107	93-7107	93-7107	93-7107	—	—
79-88	All <b>Chevelle, Malibu &amp; Monte Carlo</b>	3	93-7107	93-7107	93-7107	93-7107	—	—
80-85	All <b>Citation</b>	3	93-7107	93-7107	93-7107	93-7107	—	—
<b>CHEVROLET &amp; GMC TRUCK</b>								
82-91	All <b>Blazer &amp; Jimmy</b>	3	93-7107	93-7107	—	—	—	—
79-88	All <b>Caballero, El Camino &amp; Sprint</b>	3	93-7107	93-7107	—	—	—	—
90-96	All <b>Lumina APV</b>	3	93-7107	93-7107	—	—	—	—
82-91	All <b>Suburban</b>	3	93-7107	93-7107	93-7107	93-7107	—	—
87-91	R/V <b>C/K &amp; R/V Series</b>	3	93-7107	93-7107	93-7107	93-7107	—	—
82-86	C/K	3	93-7107	93-7107	93-7107	93-7107	—	—
81-96	All <b>G Series Van</b>	3	93-7107	93-7107	—	—	—	—
93-96	P30 (1 Ton) <b>P Series</b>	3	93-7107	93-7107	—	—	—	—
94	All—Exc. Pick-up <b>S/T Blazer, Jimmy, Pick-up</b>	3	93-7107	93-7107	93-7107	93-7107	—	—
82-91	All	3	93-7107	93-7107	93-7107	93-7107	—	—
<b>OLDSMOBILE</b>								
92-98	All <b>Aurora &amp; Achieva</b>	3	93-7107	93-7107	93-7107	93-7107	—	—
91-94	All <b>Bravada</b>	3	93-7107	93-7107	93-7107	93-7107	—	—
82-96	All <b>Calais &amp; Ciera</b>	3	93-7107	93-7107	93-7107	93-7107	—	—
90-91	88 & 98 4 dr <b>88, 98, Regency &amp; Custom Crusier</b>	3	93-7107	93-7107	—	—	—	—
90	98 4 dr	3	93-7107	93-7107	—	—	—	—
88-90	Custom Crusier	3	93-7107	93-7107	93-7107	93-7107	—	—

YEAR	MAKE / MODEL	STYLE	RIGHT FRONT	LEFT FRONT	RIGHT REAR	LEFT REAR	GEAR	TORQ PIN
88-89	All—Exc. Custom Crusier	3	93-7107	93-7107	—	—	—	—
80-87	All	3	93-7107	93-7107	93-7107	93-7107	—	—
<b>Cutlass &amp; F85</b>								
79-88	All—RWD	3	93-7107	93-7107	—	—	—	—
<b>Firenza</b>								
80-86	All	3	93-7107	93-7107	93-7107	93-7107	—	—
<b>Omega</b>								
80-85	All	3	93-7107	93-7107	93-7107	93-7107	—	—
<b>Silhouette</b>								
90-96	All	3	93-7107	93-7107	—	—	—	—
<b>Toronado &amp; Trefeo</b>								
80-92	All	3	93-7107	93-7107	—	—	—	—
79	w/4 Hole Mount	3	93-7107	93-7107	—	—	—	—
<b>PONTIAC</b>								
<b>2000, J2000, Sunbird &amp; Sunfire</b>								
82-99	All	3	93-7107	93-7107	93-7107	93-7107	—	—
<b>6000</b>								
82-91	All	3	93-7107	93-7107	93-7107	93-7107	—	—
<b>Bonneville, Catalina, Grandville, Parisienne &amp; Safari</b>								
90-91	All	3	93-7107	93-7107	—	—	—	—
88-89	All—Exc. Safari	3	93-7107	93-7107	—	—	—	—
	Safari	3	93-7107	93-7107	93-7107	93-7107	—	—
80-87	All	3	93-7107	93-7107	93-7107	93-7107	—	—
<b>Fiero</b>								
84-88	All	3	93-7107	93-7107	—	—	—	—
<b>Firebird</b>								
82-92	All	3	93-7107	93-7107	—	—	—	—
<b>Grand Am, Lemans &amp; Tempest</b>								
79-98	All	3	93-7107	93-7107	93-7107	93-7107	—	—
<b>Grand Prix</b>								
79-87	All	3	93-7107	93-7107	—	—	—	—
<b>Pheonix &amp; Ventura</b>								
80-85	All	3	93-7107	93-7107	93-7107	93-7107	93-7107	—
<b>Trans Sport</b>								
90-96	all	3	93-7107	93-7107	—	—	—	—

WINDOW PARTS



YEAR	MAKE / MODEL	STYLE	RIGHT FRONT	LEFT FRONT	RIGHT REAR	LEFT REAR	* FRT GEAR	* REAR GEAR	TORQ PIN
<b>FORD / MERCURY</b>									
<b>Colony Park, Gr. Marquis, Marquis (full size) &amp; Monterey</b>									
92-99	All	2	—	93-7121	93-7121	—	97-7760	97-7760	96-7581
90-91	All	2	93-7119	93-7118	93-7118	93-7119	97-7760	97-7760	96-7581
89	From 5/89	2/1	93-7119	93-7118	93-7110	93-7111	97-7760	68-3157	96-7581
	To 4/89	1	93-7111	93-7110	93-7110	93-7111	68-3157	68-3157	96-7581
79-88	All	1	93-7111	93-7110	93-7110	93-7111	68-3157	68-3157	96-7581
73-78	2 dr. Front & Rear Qtr. Window	1	93-7111	93-7110	93-7110	93-7111	68-3157	68-3157	96-7581
	4 dr.	1	—	—	93-7110	93-7111	—	68-3157	96-7581
65-72	All	1	93-7111	93-7110	93-7110	93-7111	68-3157	68-3157	96-7581
79-91	Tailgate	1	—	—	93-7111	—	68-3157	—	96-7581
70	Tailgate—9 Tooth Gear	1	—	—	93-7110	—	68-3157	—	96-7581
<b>Fairmont / Zephyr</b>									
78-83	All	1	93-7110	93-7111	93-7111	93-7110	68-3157	68-3157	96-7581
<b>LTD / Marquis (mid size) &amp; Granada / Monarch</b>									
75-86	All	1	93-7110	93-7111	93-7110	93-7111	68-3157	68-3157	96-7581
<b>Fairlane, Falcon, LTD II &amp; Torino / Montego</b>									
68-79	Front & Rear	1	93-7110	93-7111	93-7110	93-7111	68-3157	68-3157	96-7581
	Rear Qtr. Window—Exc. Convertible	1	—	—	93-7110	93-7111	—	68-3157	96-7581
70-72	Tailgate—9 Tooth Gear	1	—	—	93-7110	—	68-3157	—	96-7581
<b>Mustang &amp; Mustang II</b>									
84-93	Exc. Convertible	—	—	—	—	—	68-3157	68-3157	96-7581
	Convertible	—	—	—	—	—	68-3157	68-3157	96-7581
80-83	All	—	—	—	—	—	68-3157	68-3157	96-7581
71-79	All	1	93-7110	93-7111	—	—	68-3157	—	96-7581
<b>Cougar</b>									
89-97	All	2	93-7112	93-7113	—	—	97-7760	—	96-7581
87-88	All	—	—	—	—	—	—	—	—
83-86	All	1	93-7111	93-7110	—	—	68-3157	—	96-7581
81-82	2 dr.	1	93-7111	93-7110	—	—	68-3157	—	96-7581
	4 dr.	1	93-7110	93-7111	93-7110	93-7111	68-3157	68-3157	96-7581
80	All	1	93-7111	93-7110	—	—	68-3157	—	96-7581
77-79	All	1	93-7110	93-7111	93-7110	93-7111	68-3157	68-3157	96-7581
74-76	Front Door	1	93-7110	93-7111	—	—	68-3157	—	96-7581
	Rear Qtr. Window	1	—	—	93-7110	93-7111	—	68-3157	96-7581

\* 68-3157 SPRING TYPE, 97-7760 INCLUDES TORQUE PINS.

YEAR	MAKE / MODEL	STYLE	RIGHT FRONT	LEFT FRONT	RIGHT REAR	LEFT REAR	* FRT GEAR	* REAR GEAR	TORQ PIN
69-73	All	1	93-7110	93-7111	—	—	68-3157	—	96-7581
<b>Taurus / Sable</b>									
96-99	All	—	—	—	—	—	—	—	—
86-95	All	2	93-7122	93-7123	93-7123	93-7122	97-7760	97-7760	96-7581
<b>Tempo / Topaz</b>									
93-94	All	1	93-7111	93-7110	—	—	68-3157	—	96-7581
84-92	All	1	93-7111	93-7110	93-7111	93-7110	68-3157	68-3157	96-7581
<b>Thunderbird</b>									
89-97	All	—	—	—	—	—	97-7760	—	96-7581
87-88	All	—	—	—	—	—	97-7760	—	96-7581
81-86	All	1	93-7111	93-7110	—	—	68-3157	—	96-7581
80	Front Door	1	93-7111	93-7110	—	—	68-3157	—	96-7581
	Rear Qtr. Window	1	—	—	93-7110	93-7111	—	68-3157	96-7581
77-79	Front Door	1	93-7110	93-7111	—	—	68-3157	—	96-7581
	Rear Qtr. Window	1	—	—	93-7110	93-7111	—	68-3157	96-7581
74-76	Front Door—Exc. Mini Vent	1	93-7110	93-7111	—	—	68-3157	—	96-7581
	Mini Vent	—	—	—	—	—	68-3157	—	96-7581
	Rear Qtr. Window	1	—	—	93-7110	93-7111	—	68-3157	96-7581
73	Front Door	1	93-7110	93-7111	—	—	68-3157	—	96-7581
	Rear Qtr. Window	1	—	—	93-7110	93-7111	—	68-3157	96-7581
72	Front Door	1	93-7110	93-7111	—	—	68-3157	—	96-7581
	Rear Qtr. Window	1	—	—	93-7111	93-7110	—	68-3157	96-7581
67-71	Front Door	1	93-7111	93-7110	93-7111	93-7110	68-3157	68-3157	96-7581
	Rear Qtr. Window	1	—	—	93-7110	93-7111	—	68-3157	96-7581
<b>FORD TRUCKS</b>									
<b>Aerostar</b>									
91-94	All	2	93-7116	93-7117	—	—	—	—	—
90	From 11/89	2	93-7116	93-7117	—	—	—	—	—
86-90	To 11/89	1	93-7110	93-7111	—	—	68-3157	—	96-7581
<b>Bronco (full size)</b>									
93-95	All	2	93-7113	93-7112	—	—	97-7760	—	96-7581
92	From 5/92	2	93-7113	93-7112	—	—	97-7760	—	96-7581
	To 4/92	1	93-7110	93-7111	—	—	68-3157	—	96-7581
82-91	All	1	93-7110	93-7111	—	—	68-3157	—	96-7581
81	From 10/80	1	93-7110	93-7111	—	—	68-3157	—	96-7581
80-81	To 9-80	1	93-7111	93-7111	—	—	68-3157	—	96-7581

\* 68-3157 SPRING TYPE, 97-7760 INCLUDES TORQUE PINS.

WINDOW PARTS



YEAR	MAKE / MODEL	STYLE	RIGHT FRONT	LEFT FRONT	RIGHT REAR	LEFT REAR	* FRT GEAR	* REAR GEAR	TORQ PIN
78-96	Tailgate	1	—	—	93-7110	—	—	68-3157	96-7581
<b>Bronco II &amp; Ranger</b>									
88-92	All	2	93-7114	93-7115	—	—	—	—	—
87	From 11/86	2	93-7114	93-7115	—	—	—	—	—
85-86	To 10/86	1	93-7110	93-7111	—	—	68-3157	—	96-7581
90-93	Tailgate	1	—	—	—	—	68-3157	—	96-7581
<b>Explorer</b>									
91-97	All	—	—	—	—	—	—	—	—
<b>Ranchero</b>									
71-79	All	1	93-7110	93-7111	—	—	68-3157	—	96-7581
<b>E Series Van (full size)</b>									
91	All	2	—	93-7117	—	—	—	—	—
85-90	All	1	93-7110	93-7111	—	—	68-3157	—	96-7581
<b>F Series Pick-up (full size)</b>									
93-95	All	2	93-7118	93-7119	—	—	97-7760	—	96-7581
92	From 5/92	2	93-7118	93-7119	—	—	97-7760	—	96-7581
	To 4/92	1	93-7111	93-7110	—	—	68-3157	—	96-7581
82-91	All	1	93-7110	93-7111	—	—	68-3157	—	96-7581
80-81	From 10/80	1	93-7110	93-7111	—	—	68-3157	—	96-7581
	To 9/80	1	93-7111	93-7111	—	—	68-3157	—	96-7581
<b>LINCOLN</b>									
<b>Continental</b>									
93	All	2	93-7122	93-7123	—	—	97-7760	—	96-7581
88-92	All	2	93-7122	93-7123	—	—	97-7760	97-7760	96-7581
84-87	All	1	93-7108	93-7109	93-7109	93-7108	68-3157	68-3157	96-7581
82-83	All	1	93-7110	93-7111	93-7111	93-7110	68-3157	68-3157	96-7581
80-81	Front & Rear Door w/Mini Vent	1	93-7108	93-7109	93-7110	93-7111	68-3157	68-3157	96-7581
80	Front Qtr. Window	1	93-7108	93-7109	—	—	68-3157	—	96-7581
73-80	Front & Rear Door w/o Mini Vent	1	93-7110	93-7111	93-7110	93-7111	68-3157	68-3157	96-7581
	All w/Mini Vent To 11/80	1	93-7109	93-7108	93-7110	93-7111	68-3157	68-3157	96-7581
	Front Qtr. Window	1	93-7110	93-7111	—	—	68-3157	—	96-7581
<b>Mark Series</b>									
93-96	All	2	93-7118	93-7119	—	—	97-7760	—	96-7581
84-92	All	1	93-7111	93-7110	—	—	68-3157	—	96-7581
83	All	1	93-7108	93-7109	93-7110	93-7111	68-3157	68-3157	96-7581

\* 68-3157 SPRING TYPE, 97-7760 INCLUDES TORQUE PINS.



YEAR	MAKE / MODEL	STYLE	RIGHT FRONT	LEFT FRONT	RIGHT REAR	LEFT REAR	* FRT GEAR	* REAR GEAR	TORQ PIN
81-82	Front & Rear Door	1	93-7108	93-7109	93-7110	93-7111	68-3157	68-3157	96-7581
	Front Qtr. window	1	—	93-7111	—	—	68-3157	—	96-7581
80	Front & Rear Door w/Mini Vent To 11/80	1	93-7108	93-7109	93-7110	93-7111	68-3157	68-3157	96-7581
	Front Qtr. window	1	93-7110	93-7111	—	—	68-3157	—	96-7581
73-79	Front Door w/o Mini Vent	1	93-7110	93-7111	—	—	68-3157	—	96-7581
	w/Mini Vent	—	—	—	—	—	—	—	—
	Front Qtr. window	1	93-7110	93-7111	—	—	68-3157	—	96-7581
72	Front Door	1	93-7110	93-7111	—	—	68-3157	—	96-7581
	Front Qtr. window	1	93-7111	93-7110	—	—	68-3157	—	96-7581
69-71	All	1	93-7111	93-7110	—	—	68-3157	—	96-7581
	<b>Town Car</b>								
90-99	All	2	93-7121	—	—	93-7121	97-7760	97-7760	96-7581
89	All	1	93-7108	93-7109	93-7111	93-7110	68-3157	68-3157	96-7581
81-88	All	1	93-7108	93-7109	93-7110	93-7111	68-3157	68-3157	96-7581
	<b>Versailles</b>								
77-80	All	1	93-7108	93-7109	93-7110	93-7111	68-3157	68-3157	96-7581

\* 68-3157 SPRING TYPE, 97-7760 INCLUDES TORQUE PINS.

WINDOW PARTS

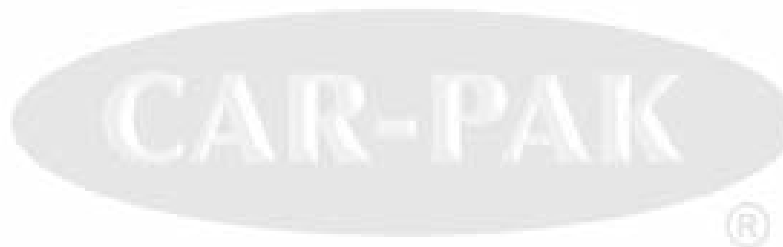

[www.carpak.com](http://www.carpak.com)



CAR-PAK MANUFACTURING COMPANY, INC. • TROY, MI



## POWER WINDOW MOTOR GEARS

### SUGGESTED METHOD TO REPAIR G.M. STEEL POWER WINDOW MOTOR

Use cold chisel to remove rivets and perforated metal holding both halves of motor together. Remove retaining push nut from shaft motor. Disassemble motor being extremely careful to keep electrical parts intact.

Remove gear and replace with new gear. (If this gear is not the problem, this repair kit will not do the job.)

Replace electrical parts, replace steel cover and using the supplied bolts and lock nuts. Note the two sizes of bolts & nuts. You may have to run a drill bit through the holes left by the sheared metal retainer.

Replace new push nut onto shaft and seat for maximum retention.

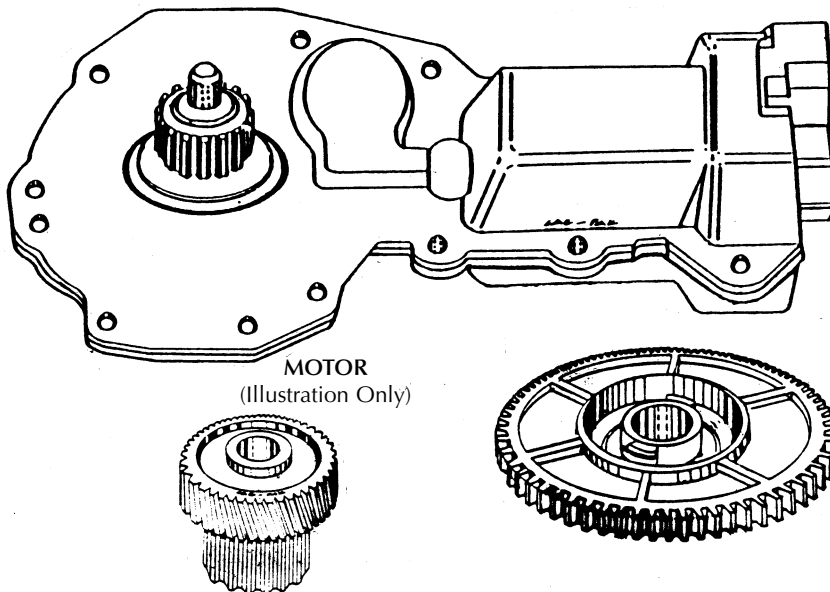

**83-5622**

GEAR ONLY  
Plastic

UNIT PACKAGE 1

**82-5509**

GEAR ONLY  
w/Screws & Nuts  
Plastic

UNIT PACKAGE 1

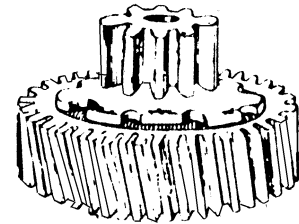

**68-3157**

C9AZ-62234A24, D0AZ-62234A24A  
GEAR-POWER WINDOW REGULATOR  
(9 Tooth Metal/45 Tooth Plastic)

Ford '64/  
UNIT PACKAGE 1

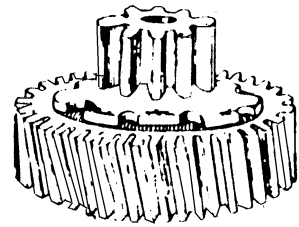

**70-3411**

D0VY-53234A24A  
TAILGATE-POWER WINDOW GEAR  
(7 Tooth Metal/45 Tooth Plastic)  
Ford Products Station Wagon '70/  
Station Wagon Tailgate Also All  
Ford Products Electric Windows  
With Vent Glass

UNIT PACKAGE 1



**68-3158**

(2808914)  
GEAR-POWER WINDOW REGULATOR  
(9-Tooth)

Chrysler '64 - '75  
UNIT PACKAGE 1

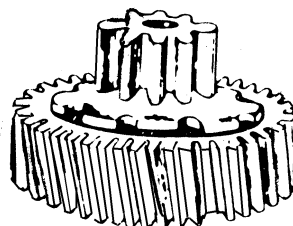

**77-4628**

GEAR-POWER WINDOW REGULATOR  
(9 Tooth Metal/41 Tooth Plastic)

Chrysler '75-'89  
UNIT PACKAGE 1

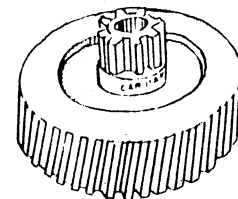

**80-5284**

GEAR-POWER WINDOW REGULATOR  
(9-Tooth)

American Motors  
UNIT PACKAGE 1

**REPLACEMENT GEAR & TORQUE PINS FOR WINDOW MOTORS**

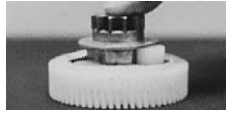

Typical Gear Assembly

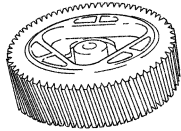

**97-7746**

Not Supplied By O.E.  
**GEAR**-for Power Window Regulator  
 2-1/2" O.D. Nylon Gear Only  
 Ford '89/  
*UNIT PACKAGE 1*

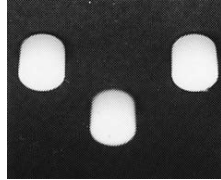

**96-7581**

**TORQUE PIN KIT**  
 Kit Contains 3 Torque Pins  
 Ford '64/, Chrysler '64/  
*UNIT PACKAGE 5 (Kits)*

**97-7760**

Not Supplied By O.E.  
**KIT**-for Power Window Regulator  
 Contains: 1-2-1/2" O.D. Nylon  
**Gear (97-7746)**  
**3 Torque Pins (96-7581)**  
 Ford '89/  
*UNIT PACKAGE 1 (KIT)*

**INSTRUCTIONS**

1. Remove Gear from Motor

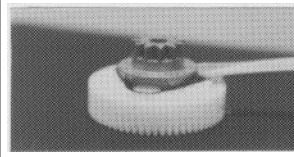

2. Separate Metal & Nylon Gear

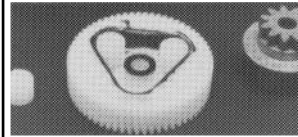

4. Position 2 New Torque Pins in Nylon Gear

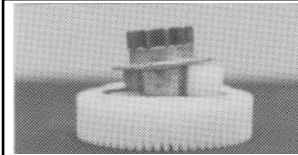

6. Position 3rd Torque Pin

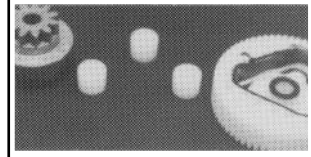
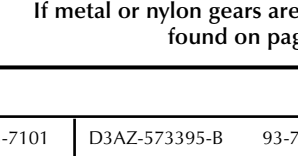

3. Remove Worn Torque Pins

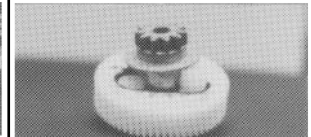

5. Position Metal Gear with 2 Torque Pins in Place

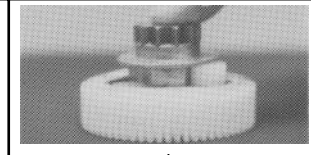

7. Press Metal Gear Down Until Fully Seated

**If metal or nylon gears are damaged, use Car-Pak gears found on page 62 of catalog.**

WINDOW PARTS

<b>GM P/N</b>	<b>C-P NO</b>	20421231	93-7107	22048533	93-7101	D3AZ-573395-B	93-7111	E6DZ-5423395-A	93-7122
5048904	93-7107	20421232	93-7107	22049766	93-7107	D3AZ-6523394-A	93-7110	E8OY-5423394-A	93-7122
5048907	93-7107	20435573	93-7107	22062528	93-7107	D3AZ-6523395-A	93-7111	E8OY-5423395-A	93-7123
5048908	93-7107	20435574	93-7107	22087327	93-7107	D7WY-6523394-A	93-7110	E8TZ-9823394-A	93-7110
12362900	93-7107	20435575	93-7107	22087328	93-7107	D7WY-6523395-A	93-7111	E9AZ-5423394-A	93-7118
12362901	93-7107	20450532	93-7107	22121553	93-7107	D8TZ-9823394-A	93-7110	E9AZ-5423394-B	93-7119
12512994	93-7107	20480564	93-7107	22144260	93-7107	D8TZ-9823395-A	93-7111	E9AZ-5423395-A	93-7119
14012381	93-7107	22010457	93-7107	22154371	93-7107	D9BZ-3623394-A	93-7110	E9AZ-5423395-B	93-7118
14012382	93-7107	22010458	93-7107	93412387	93-7107	D9BZ-3623395-A	93-7111	E9SZ-6323394-A	93-7112
14033699	93-7107	22020291	93-7107	93412388	93-7107	D9BZ-5423394-A	93-7110	E9SZ-6323395-A	93-7113
14033700	93-7107	22020900	93-7107	93413451	93-7107	D9BZ-5423395-A	93-7111	F09Z-1123394-A	93-7116
14056095	93-7107	22021670	93-7107	93413452	93-7107	E0VY-6623394-A	93-7108	F09Z-1123395-A	93-7117
14056096	93-7107	22029187	93-7107	<b>FORD P/N</b>	<b>C-P NO.</b>	E0VY-6623395-A	93-7109	F0VY-5423394-A	93-7120
20105348	93-7107	22029188	93-7107	D0AZ-5323394-A	93-7110	E1VY-6623394-A	93-7108	F0VY-5423395-A	93-7121
20105349	93-7107	22029191	93-7107	D0AZ-5323395-A	93-7111	E1VY-6623395-A	93-7109	F1TZ-1023394-A	93-7114
20105350	93-7107	22029192	93-7107	D0AZ-5723394-A	93-7110	E3AZ-5423394-A	93-7110	F1TZ-1023395-A	93-7115
20201150	93-7107	22029848	93-7107	D0AZ-5723395-A	93-7111	E3AZ-5423395-A	93-7111	F2VY-5423394-A	93-7121
20201151	93-7107	22030445	93-7107	D2OZ-5323394-A	93-7110	E43Z-5423394-A	93-7110	F2VY-5423394-B	93-7121
20220048	93-7107	22030651	93-7107	D2OZ-5323395-A	93-7111	E43Z-5423395-A	93-7111	F2VY-5423395-A	93-7120
20299831	93-7107	22030652	93-7107	D3AZ-5723394-A	93-7110	E5TZ-1023394-A	93-7110	F2VY-5423395-B	93-7120
20325087	93-7107	22039707	93-7107	D3AZ-5723394-B	93-7110	E5TZ-1023395-A	93-7111	F4TZ-1523394-A	93-7119
20329501	93-7107	22039929	93-7107	D3AZ-5723395-A	93-7111	E6DZ-5423394-A	93-7123	F4TZ-1523395-A	93-7118

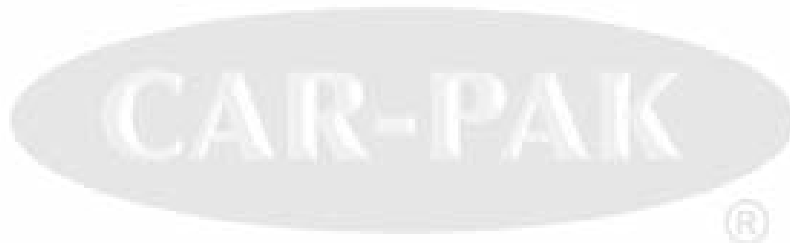

[www.carpak.com](http://www.carpak.com)